

FORTY-SIXTH THOUSAND

• **LETTERING** •
FOR
DRAFTSMEN,
ENGINEERS.
AND STUDENTS.
A
PRACTICAL SYSTEM
OF
FREEHAND LETTERING
FOR WORKING DRAWINGS.

REINHARDT.

D. VAN NOSTRAND CO., PUBLISHERS.
NEW YORK.

LETTERING
FOR
DRAFTSMEN, ENGINEERS AND STUDENTS

A PRACTICAL SYSTEM
OF FREEHAND LETTERING FOR WORKING DRAWINGS.

BY
CHAS. W. REINHARDT

(Former Chief Draftsman, Engineering News.)

FOURTEENTH EDITION, REVISED AND ENLARGED
FORTY-SIXTH THOUSAND

NEW YORK:
D. VAN NOSTRAND COMPANY,
1917.

Copyright, 1895.

Copyright, 1917.

D. VAN NOSTRAND COMPANY

PREFACE TO FIRST EDITION.

IN looking over the books on lettering, which have come under the writer's notice, he has found, that while doing full justice to the principle of ornamentation and the theories governing the shaping of each letter, no author has as yet attempted to treat lettering from a purely practical point of view. The need of a practical work on lettering, however, has been and is daily experienced by many draftsmen, and in the following pages the writer has endeavored to set forth the proper methods of forming purely free-hand lettering in a simple, easily acquired way, giving, at the same time, the proper safeguards against the errors most commonly committed. The letters exhibited are actual free-hand work and can readily be copied. In this respect the writer has made a radical departure from works of a similar character which generally give ornate, carefully engraved alphabets, being of little more use to the average draftsman than ordinary printed type, i. e., they can only be copied with a great sacrifice of time and patience. The whole system outlined is the result of the writer's experience during years of practice on the staff of a leading technical journal and is intended to be a thoroughly practical guide for doing the best class of work in the shortest possible time.

BROOKLYN, *September*, 1895.

CHAS. W. REINHARDT.

CONTENTS

TEXT	PAGE
Inclined Lettering.....	7
Lower Case Letters.....	9
Capital Letters.....	11
Numerals.....	13
Upright Lettering.....	15
Lower Case Letters.....	16
Capital Letters.....	18
Numerals.....	21
Extended Form.....	22
Freehand Lettering Applied to Working Drawings.....	24
Various Freehand Alphabets.....	28
Greek Alphabet.....	31
Lettering of Titles.....	32
Practice Sheets.....	34
Round Writing.....	36
Lettering for Photo-reproduction.....	37

PLATES
I. Specimen Sheet.
II. Map Lettering.
III. Lettering of Structural Design.
IV. Italic and Modified Freehand Alphabet.
V. Spurred Gothic.
VI. Plain Gothic.
VII. Roman Lettering.
VIII. Greek Alphabet with Application.
IX. Construction of Titles (by Aid of Counting Letters, etc.).
X. " " " " (Two Unusual Shapes).
XI. Various Specimens of Titles.
XII. " " " "
XIII. Round Writing.
XIV. Specimens of Lettered Drawings, Meridians, Scales.
XV. Cross-section, Millimeters. (Detached.)

PREFACE TO TWELFTH EDITION.

The encouraging reception given to former editions of this book has convinced the writer of the practical usefulness of the system of lettering which he advocates, and has induced him to add material which tends to enlarge the scope of the book, making it complete in every respect.

The subject of lettering, as applied to working drawings and the construction of titles, has been taken up more in detail, and the chapter devoted to lettering for purposes of photo-reproduction will be found interesting and useful by many readers. Besides the extension of the text some twelve illustrations and four full-page plates have also been added, thus considerably enlarging the work, which, it is hoped, will continue to prove a desirable hand-book to those wishing to acquire the art of freehand lettering in a simple and rational way.

C. W. R.

PREFACE TO FOURTEENTH EDITION.

With profound gratitude I noted a continued appreciation of this little treatise by the profession in general. Observing, though, that some chapters were in need of supplementing, I compiled additional material: The analyzed Greek Alphabet, the plates containing various methods of laying out and constructing titles, as well as the practice sheets, have given this book a more rounded aspect, and, I sincerely trust, will increase its usefulness.

ARLINGTON, N. J., January, 1917.

C. W. R.

INCLINED LETTERING.

IN the following system of lettering no attempt has been made to imitate any special form of printed alphabet, and for all ornate and elaborate lettering the draftsman is referred to some one of the many published collections of this character. What is here intended is to illustrate and describe a type of lettering that looks well upon working drawings; is reduced to its simplest form; one that is rapidly made and is clear and distinct under almost any reduction by photography. It is, in fact, especially designed for photo-reproduction. With the purpose of fairly treating the subject, the lettering here illustrated has been reproduced without any attempt at touching up or cleaning; it is actual freehand work, such as should be used in general practice.

The ordinary slanting and, further on, the upright lettering are described in a somewhat detailed manner, as when the draftsman once becomes proficient in form-

ing these two types properly, it will then be a very easy matter for him to form also the more ornamental letters satisfactory. The first requisite is to produce sharp, clean corners and bold lines of uniform strength, and this is especially necessary in work for photo-reproduction, as usually such apparently unimportant things as filled-in corners and uneven lines are greatly exaggerated on the plate. In Fig. 1 the correct and incorrect ways of doing this are shown. It will be well at first, for the purpose of obtaining clean corners, to resort to the

One Stroke Lettering

Incorrect.

One Stroke Lettering

Correct.

One Stroke Lettering

Fig. 1.

(Leonardt's 516 F.) most satisfactory; for medium sized

artifice of slightly curving the lines outwards at their ends, as exhibited on the third line of Fig. 1. For very large letters the writer finds a "ball-point" pen

letters, not less than 2 millimeters high, he uses Soennecken's No. 108 or 208, and for small sized letters, Gillott's No. 303, or the "Lithographic" pen. Esterbrook's pens; "Fine Business 97," "Double Spring 126" or "127" have also been found serviceable for coarser work. All of these pens should be "broken-in" somewhat before being applied to lettering; they should also be frequently cleaned when using waterproof ink, especially the "Soennecken" pens. The nibs of the pen should, while doing this, be worked back and forth gently against a soft rag, which process will cause the dried up particles of the ink to drop out from between them.

As to the type of lettering to be employed, the slanting letter is well adapted to descriptive matter, dimensions, etc., while the upright letter will contrast well with the former type used as reference letters or sub-captions. A uniform pressure should be brought to bear upon the pen—a trick only acquired by practice. The pen should be held pointed forward, as in ordinary writing, and not sideways, as in "round writing." In lettering on tracing linen a sheet of black cross-section paper divided to millimeters, such as given on detached plate (XV) accompanying this book, will be found useful for indicating

the proper spacing, slant, etc. On drawing paper, pencil guide-lines will be indispensable to the beginner.

A slope of 1 to $2\frac{1}{2}$ is sufficient for the stems or down-strokes of the letters, and ordinarily an angle of 45° with the horizontal will suffice for the upstrokes and the axis of ellipses, excepting that of the letter "o." The latter angle will have to be increased, of course, when the lettering is compressed, as shown in Fig. 2. In lower case letters, like "b" or "p" with part extend-



Fig. 2.

The exception is the lower case "t" which is one part less in total height than "b" or "h," for example. In the illustrations following, the incorrect forms of letters, as being constantly observed by the writer, are shown in brackets, and the correct method of forming each letter is shown beneath.

Lower Case Letters.

The letters "n" and "m," Fig. 3, should be made with almost sharp upper corners; "u" is best formed by three strokes, as in this way parallel

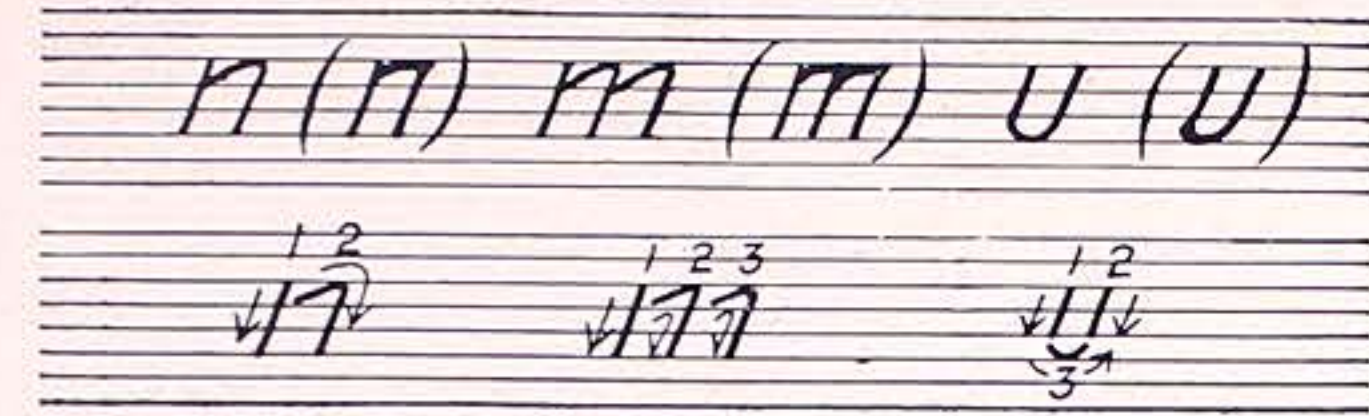

Fig. 3.

positions are secured for the straight lines, which should be made first, and these can be then joined by a lower curve. In forming the letter "v," Fig. 4, make the first stroke nearly vertical,

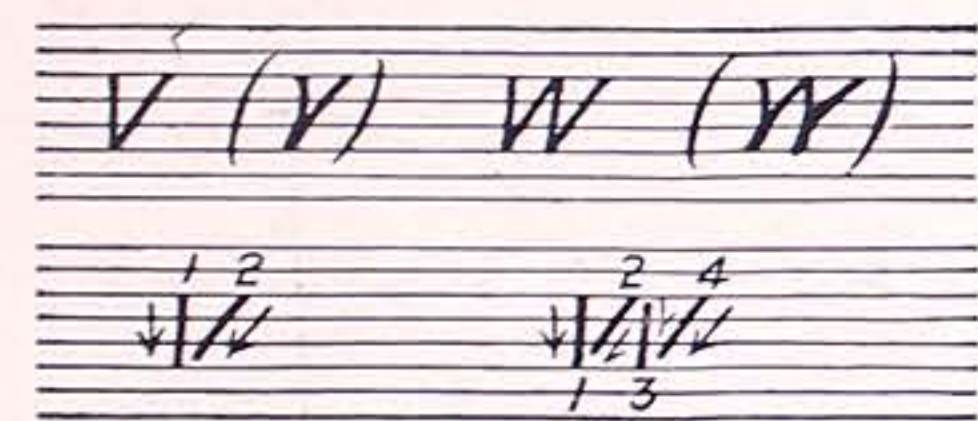

Fig. 4.

and the second at an angle of about 45° with the horizontal. The common error in making this letter lies in curving the two lines and giving the letter the appearance of a "y." The letter "w" is formed on the same principle as the "v." In putting in the short horizontal cross-line of the

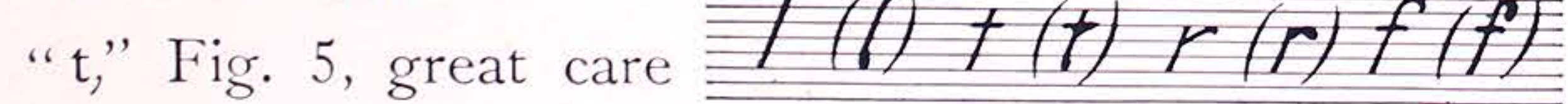

Fig. 5.

"t," Fig. 5, great care should be taken to use very little pressure upon the pen, as otherwise the ink

will spread at the intersection of the two lines and make clean corners impossible. The second part of the letter "r" should be purely an up-stroke, slightly curved at its end. In making the letter "f," start with a curve extending down about one space; the "f" shown in brackets would come out with a heavy black knob

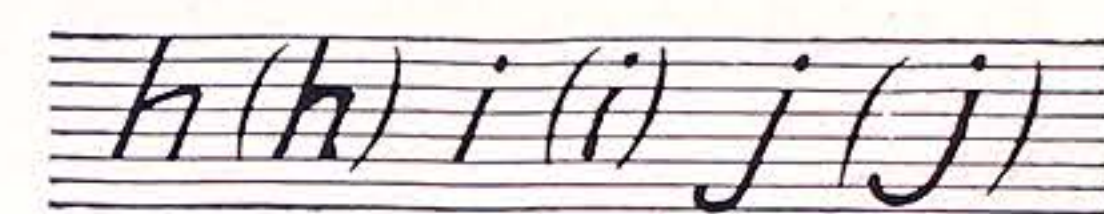

Fig. 6.

at top in any considerable reduction. The rule laid down for forming the "n" may also be applied to the letter "h," Fig. 6, and the down-stroke for the "j" is practically the same as for the "f" reversed. Make bold, oblong dots over the "i" and "j."

The third stroke of the letter "k," Fig. 7, should be vertical and begin at about the middle of the second stroke. In constructing the letter "x," care



Fig. 7.

should be taken to have the first stroke either vertical or leaning slightly backwards, and the second stroke ought to cross the first a little above its centre; in order to produce a clean intersection it may be well to make

the latter stroke in two parts. The letter "y," Fig. 8, should be drawn on the lines of the "v," and

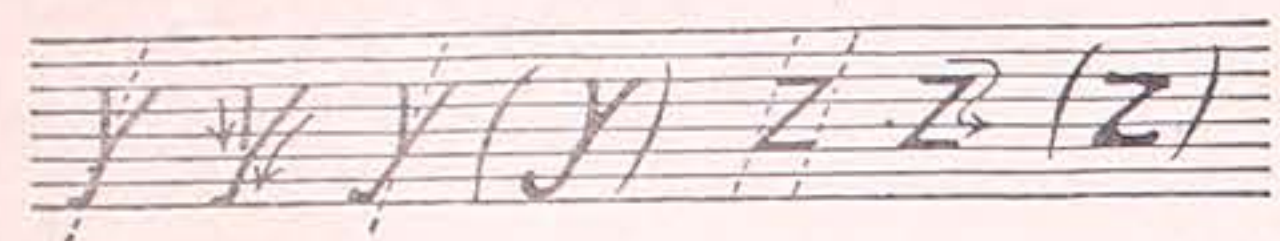

Fig. 8.

from the point of the angle the tail should be drawn in exact line with the upper down-stroke, terminating, if desired, in a slight curve to the left, to avoid the little blot of ink which would otherwise form at the bottom of the stroke. In this letter the second stroke may be modified as shown. The "z" is best drawn in one stroke, stopping the pen every time before changing direction. The letter "o," Fig. 9, is produced by two curved strokes, with their ends sufficiently bent, forming a perfect ellipse, the axis of which lies in the direction of the down-stroke. The joining of these two curves, in this and similar letters, can be effected very neatly after a little practice.

The ovals of the following letters should be made somewhat narrower at the top than at the bottom, for obvious reasons; and especial care must be taken to have the axis of these ovals lie at an angle of 45° with the horizontal. For the purpose of increasing the width of the enclosed space at the bottom of the down-stroke and the oval, the right-hand curve should be somewhat

flatter than the opposite one. For the advantages of so doing see Fig. 9. In these letters the down-stroke should be at exactly the proper angle, rather increasing this angle at the be-

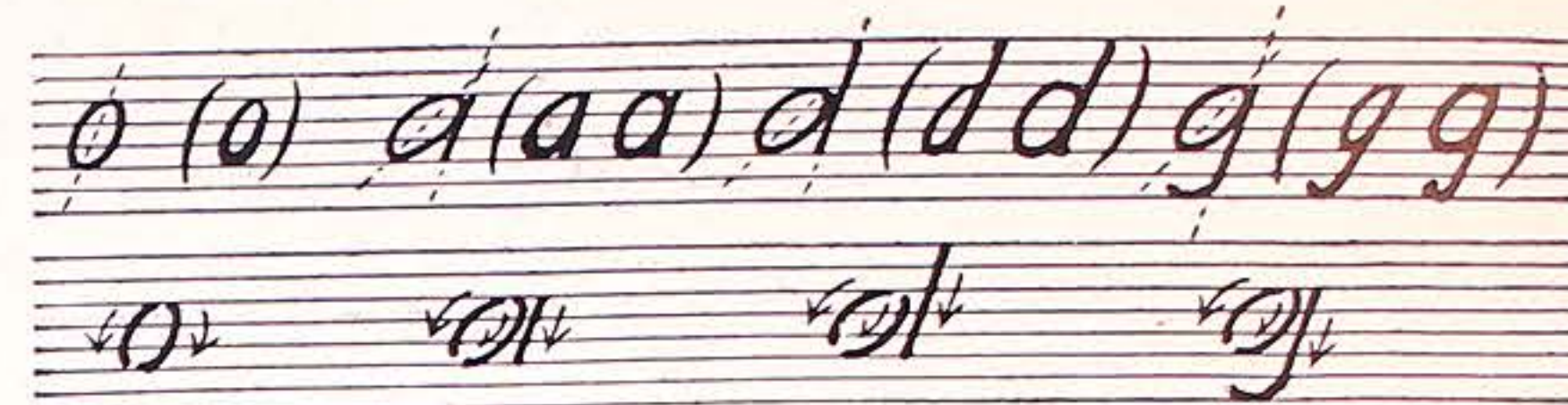

Fig. 9.

ginning, for the learner almost invariably makes the mistake of drawing this stroke too slanting. To further guard against this error, the beginner may slightly curve the end of the down-stroke towards the left, thus widening the angle at the bottom of the "a" and "d," and the down-stroke of the "g" should be made as long as possible in its straight part by turning very short with the lower left-hand curve. The letters "p" and "b," Fig. 10, should

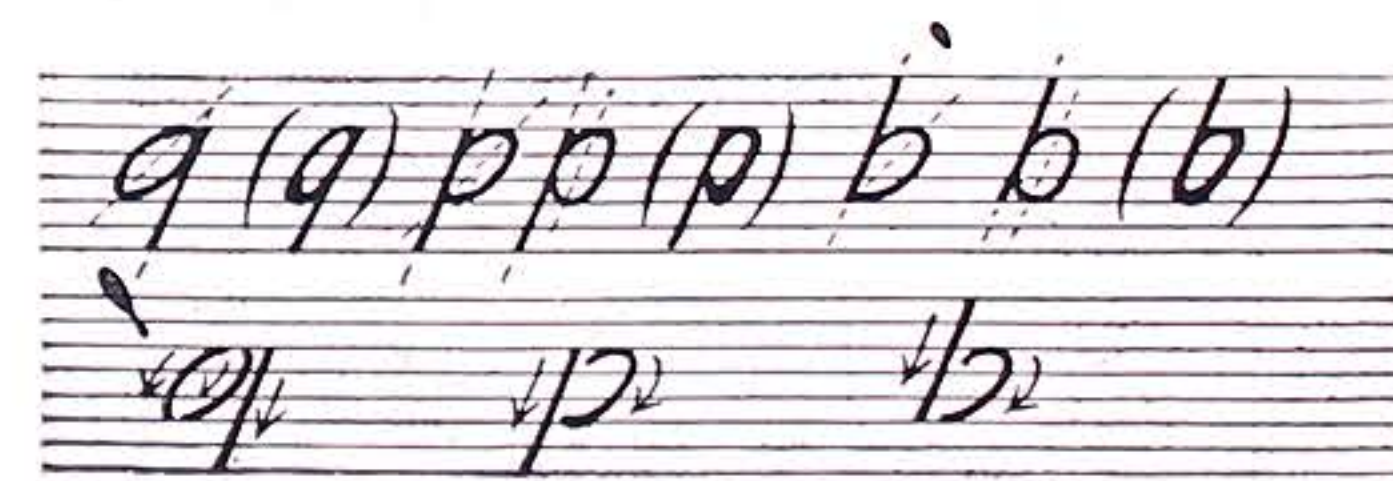

Fig. 10.

be shaped exactly as inverted letters "d" and "q." With practice these letters can also be made to look well by using the oval of the letter "o."

The letter "c," Fig. 11, is formed with one stroke, care being taken to have its general direction parallel to

the down-stroke. The "e" is commenced in the same way, and the upper loop is formed by a second stroke

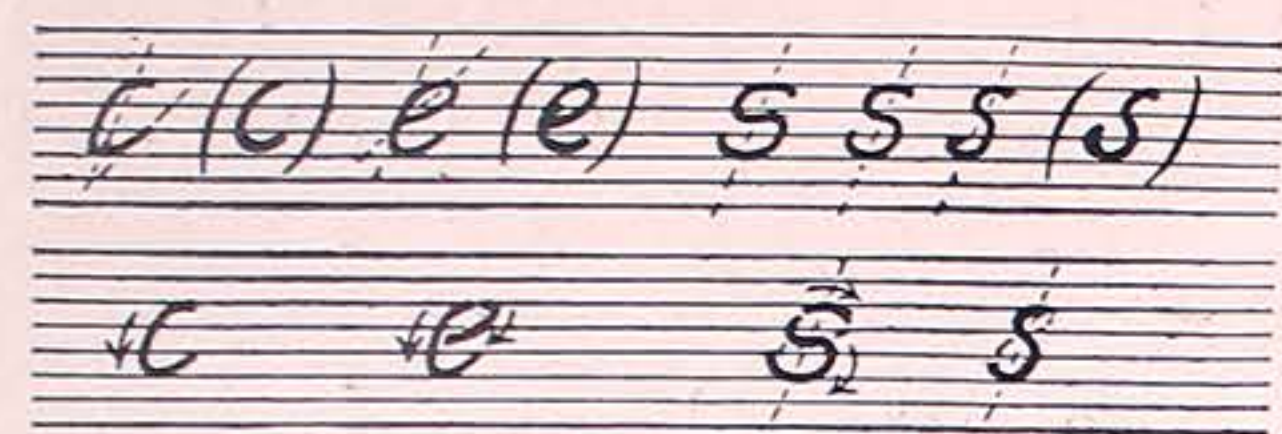

Fig. 11.

with the axis of the loop again at an angle of 45°. The beginning of the "s" is a very short curve from left to right at its apex; the rest is carefully joined on, turned down into a neat ogee curve and finished by a little crook upwards. The middle part of this letter should be nearly horizontal.

If a very narrow letter is to be produced, it may be constructed with one stroke and a flatter curve, making the upper curve somewhat shorter than the lower one. In the ordinary letter a first separate stroke at the top is

made necessary by the fact, that while turning in a horizontal direction from right to left and then descending into the ogee curve, the pen will either clog up and not give the required strength of line at one stroke or otherwise will in turning detach minute particles of paper or tracing-cloth saturated with ink and deposit them at the side of the stroke, necessitating erasures. The method outlined (employing two strokes) is therefore by far the simplest and quickest way of producing a clean letter, as experience will show. It will at first be a somewhat difficult matter to the beginner to lay the main axis of this letter parallel with the down-stroke, but this is nevertheless an essential point and should not be lost sight of.

Capital Letters.

As in the rule laid down for the lower case letters, the capital letters will generally be five spaces high. Sharply defined clean corners are again necessary, and to secure this the beginner may find it advantageous to curve the upper and lower ends of the down-strokes a little outwards.

The letter "A," Fig. 12, should be made in three strokes, with the second almost vertical. The cross-stroke should be placed low—about the middle of the second space from the bottom. The short third



Fig. 12.

stroke of the "E" should be slightly above the center of the letter, and should not be too short. The two down-strokes of the letter "H," Fig. 13, should be exactly parallel, and the horizontal stroke should be made as directed for the third stroke of the "E." If the capital "I" is to be followed by a lower case "l," two short horizontal strokes of even length and projection may be

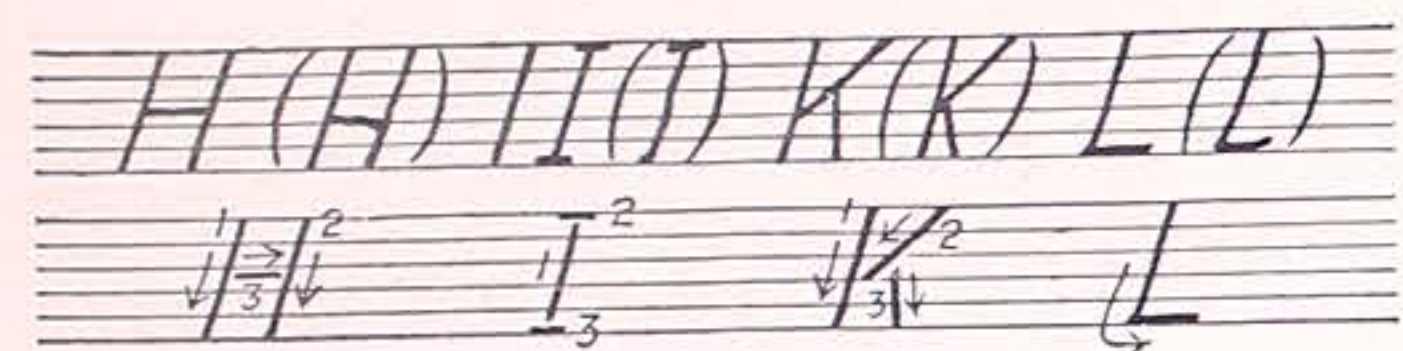

Fig. 13.

added to the top and bottom. The second stroke of the letter "K" should join the first at the top of the second space from the bottom, and the third stroke should join the second nearly one space higher up. The letter "L" can easily be made with one stroke, analogous to the forming of the same stroke of the letter "E."

The "J," Fig. 14, is commenced as a perfectly straight down-stroke to the top of the lower space; then it turns to the left in a gentle curve, tangent to the base line, and finally rises to the top of the first space. The "M" is made with four separ-



Fig. 14.

ate strokes, putting in the two parallel lines first; the two other strokes should join at the top of the first space. If desired, this letter may be made slightly wider at the bottom than at the top. The letter "N" is also formed by drawing the two parallel strokes first. The horizontal stroke of the "T" should be neatly balanced on top of the down-stroke, and if it is not perfectly straight, as often is the case, a hardly noticeable crook downwards

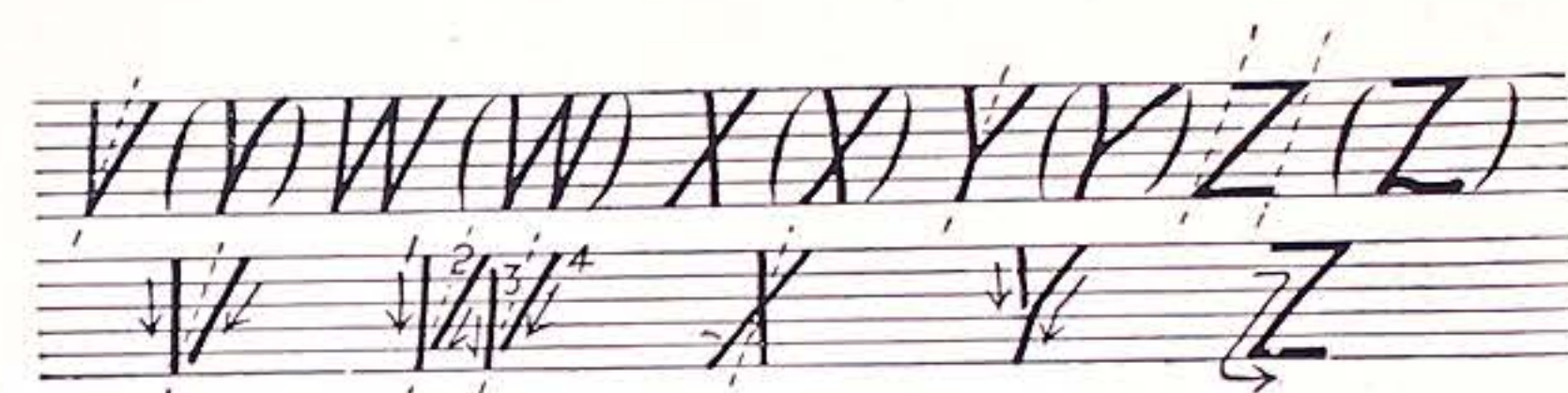

Fig. 15.

at both ends will improve it. The letters shown in Fig. 15 are to be constructed precisely upon the lines laid down for the corresponding lower case letters, with the exception that they should be a trifle narrower in proportion. The "Y" is formed with two strokes without any lower crook to the left; the "Z" is made in one stroke, with the axis of the letter in the direction of the down-stroke. If



Fig. 6

found easier, this "Z" can be made with three strokes.

With practice the letters "P," "B" and "D" can each be formed with two strokes, with the curves terminating as shown. In forming the two curves of the letter "B," begin at the top, and after joining the stem, return exactly on the horizontal while the ink is yet moist and complete the lower curve. The space enclosed by the lower curve should be somewhat larger than that in the upper one. The curve of the "D" should be parallel with the down-stroke in its middle third, but it may sometimes be advisable to make the lower part of the "D" a shade wider than the upper part. The first and second strokes of the "R" are identical with the letter "P."

The "C," Fig. 17, is formed with one stroke, nearly completing the ellipse of the letter "O," though this let-

ter should be proportionately narrower than the lower case "c." In making the "G," a somewhat wider ellipse is required, and this letter is most easily made with two strokes; the second horizontal stroke should be about



Fig. 17.

one-half of the total width of the ellipse.

The capital "O" should be an almost perfect ellipse, special care being taken in joining the two curves. The third stroke of the "Q" should begin about the middle of the second space, and extend one space below the base. The letter "S" can be formed, for small-sized lettering, in two strokes, or with an additional stroke, as shown, for larger letters.

Numerals.

As a rule, numerals should occupy the same height as capital letters, or five spaces, though the use of fractions may slightly modify this rule. When the numeral "1," Fig. 18,

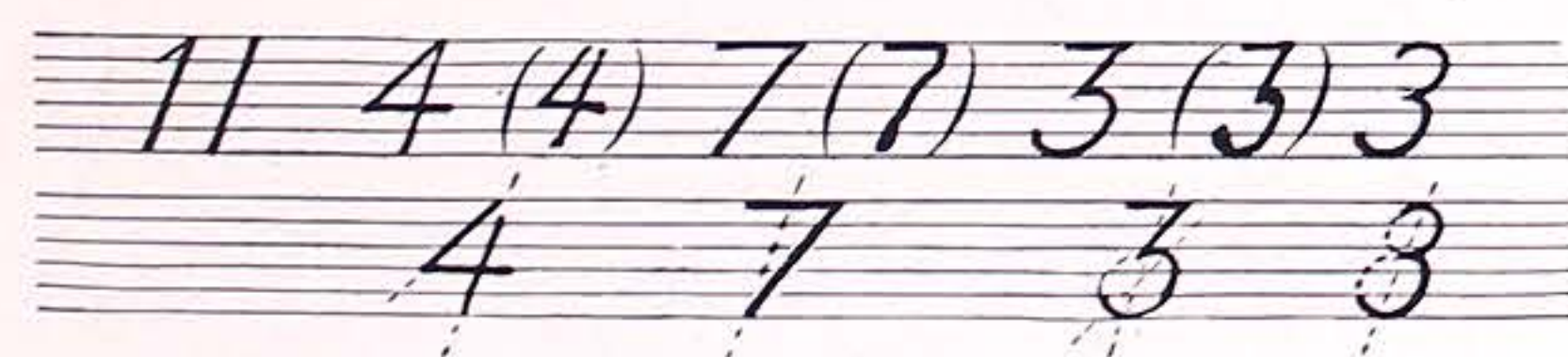
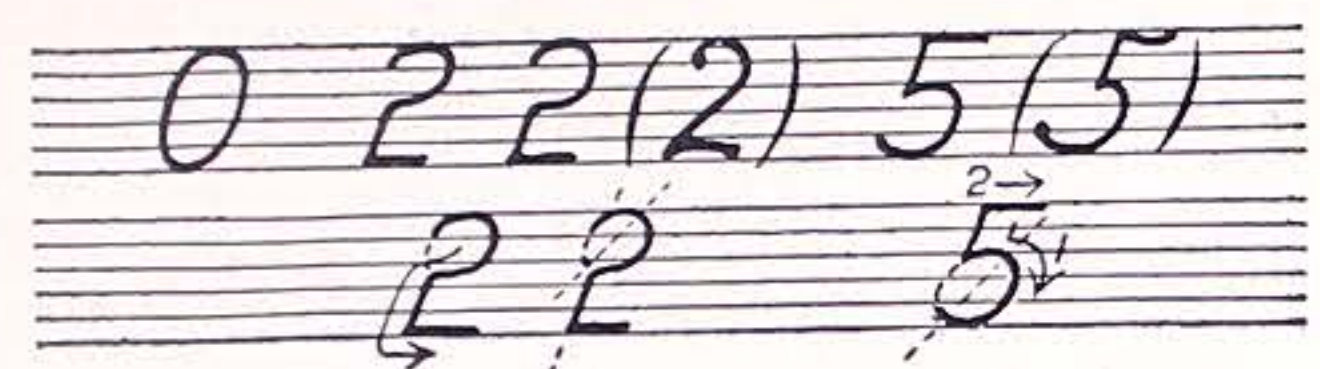

Fig. 18.

as capital letters, or five spaces, though the use of fractions may

is used in proximity with "I" or "l," it is well to use a short up-stroke at the top; otherwise, it may be represented by a simple down-stroke. The "4" is commenced with the stroke inclined at an angle of 45°, terminating at the second space from bottom and then turning sharply into the horizontal. The down-stroke should intersect

the horizontal in such manner as to leave about 3-5 of the horizontal to the left of the down-stroke. The "7" is best formed with one stroke, the down-stroke being on an angle of 45°. The "3" should be drawn in one stroke, beginning as with the "7" to a point a little below the top of the third space, and then curving into a portion of an ellipse, with an axial angle of 45°. Another type of the numeral "3" is shown, which can be made in one stroke also.



The "o" Fig. 19,

Fig. 19.

ought to be a perfect ellipse, like the capital "O." The "5" is commenced with the down-stroke, ending in the ellipse of the "3" and the horizontal upper stroke. The "2" can be constructed by one stroke, beginning at the top of the fourth space, nearly completing an oval with an axial angle of 45°, and then turning shortly into a down-stroke running into the base line, where a sharp

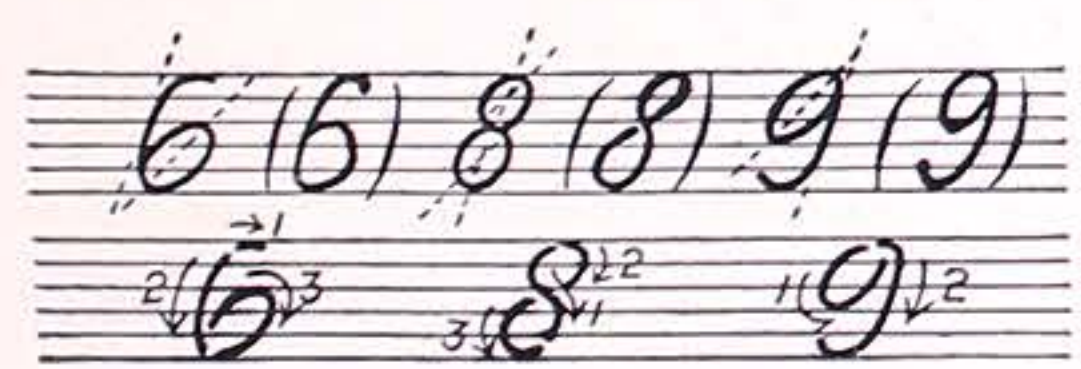

Fig. 20.

turn is made in a horizontal direction. The "6," Fig. 20, is commenced like the "o," except that its initial point is somewhat beyond the axis of the ellipse. For that rea-

son the first stroke is very short, curving to the right; the second stroke descends nearly to the base, where a stop is made, and the pen then returns in the same stroke, and, gradually turning to the right, nearly completes an ellipse with an axial angle of 45°, joining its lower part with the bottom of the incomplete second stroke. The figure "8" is commenced with an ogee curve, using a slight crook at its lower end, and is finished by two other curves, as shown. The lower loop should always be somewhat larger than the upper one. The numeral "9" is made in two strokes. The ellipse at the top is nearly finished in one stroke when the down-stroke is assumed, which, beginning at the initial point of the ellipse and completing the latter, terminates with a somewhat fuller curve than that employed in lower case "g."

Though Roman numerals are seldom employed on working drawings, they may sometimes be required. The chief requisite is to so form them that they are neat in appearance and easily distinguished from the rest of the text. They should be of the same height as the Arabic numerals, and short horizontal strokes



Fig. 21.

should be used with them, as indicated in Fig. 21.

In the modified forms shown in Fig. 22 it will be noticed that all the letters and numerals are based upon the general form of the letter "o," modified to suit demands. The second stroke of the "r" is really a part of the elementary ellipse, as are also the second stroke of the "n" and the second and third strokes of the "m." The "u" is here made in two strokes—the first, a down-stroke with the curve attached, and the

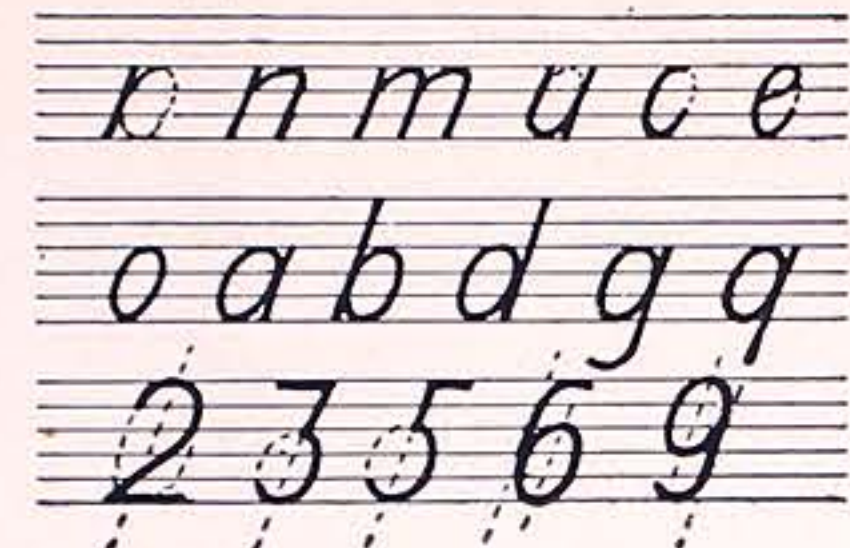

Fig. 22.

second a straight down-stroke, tangent to and touching the curve.

The numerals follow similar lines of construction. The "2" begins at the upper part in an ellipse and ends in a down-stroke, laid at an angle of 45°, turning sharply to the right in a horizontal line. The "3" is formed with one stroke, with its lower curve, as also that of the "5" and "6," encircling somewhat more than half of the ellipse. In the "6" and "9" care must be taken to have the curved down-strokes only tangent to the respective ellipses, and not cutting off a portion of the latter.

UPRIGHT LETTERING.

Upright lettering is employed most advantageously for reference letters, designating lines of section, and for captions. In some instances however, it may be deemed advisable to use uprights also for such descriptive matter, dimensions, etc., to which some prominence

is to be given, though, as a rule, the slanting lettering will answer this purpose very well.

The relative height of the letters ought to remain the same as that of the inclined lettering. The down-strokes should be perfectly vertical, and in order to pro-

duce this effect properly, it will be best for the beginner to form the habit of making the letters at first lean over somewhat to the left at the top, as the natural tendency would be to have them lean the opposite way. It will be noticed that in some of the uprights a comparatively greater number of strokes is required, as many portions of

these letters are being executed in a horizontal direction or nearly so. The letters are again simplified as much as possible, a fact which will be especially noticeable in the lower case "a" and "g," which, though at variance with the ordinary gothic print, look fully as well.

Lower Case Letters.

In the letters shown in Fig. 23, the same number of strokes is employed as in the slanting lettering previously described. The letters are as a rule made wider than those of the slanting type. The second stroke of the "n" and the two last strokes of the letter "m" are started with a very slight curve in an upward direction rounding off the corner at the top, making it somewhat more full than in the corresponding slanting letters.

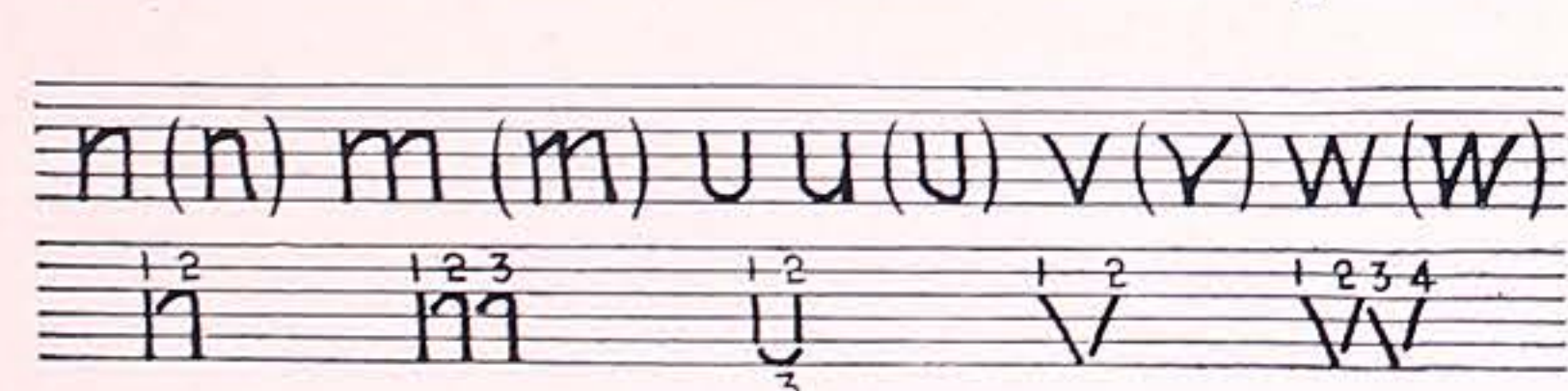

Fig. 23.

connecting the two down-strokes with a well shaped curve. If preferred, however, the ordinary form of gothic lower case "u," as

The letter "u" is made in three strokes as usual,

shown, may also be employed. In constructing the letter "v," the two slanting strokes ought to make the same angle with the vertical. The beginner will invariably construct the second stroke at a greater incline than the first, and will do well to guard against this habit, until after some practice the hand will become accustomed to form the point of juncture of the two strokes equidistant from their starting point. The letter "w" is composed practically of two somewhat narrowed "v"s.

The letter "l" (Fig. 24) is sometimes constructed with a lower crook to the right, when used at the side of capital letter "I," otherwise it is made as a down-stroke pure and simple. The second stroke of the "r" starts

from the top of the second space upwards as a very slight curve, similar to the one forming first part of the second stroke of letter "n." Letter "f" is best formed by three strokes; the first a very short curve to the right, being joined by the second or main stroke. The

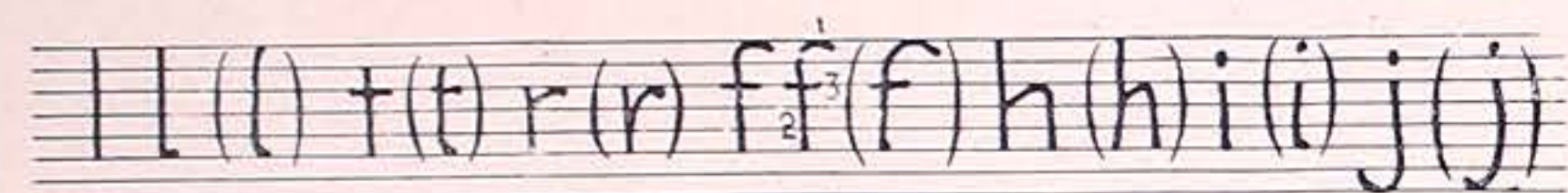

Fig. 24.

horizontal third stroke should be made sufficiently prominent.

The letter "j" ought to extend two spaces below the base line and should be made in one stroke, being perfectly straight until the point of curve is reached. If found easier, however, a second right hand stroke, forming the curved portion, may be employed. The latter should be almost a semicircle and one space high.

The second stroke of letter "k" (Fig. 25) should extend down to nearly the first space.

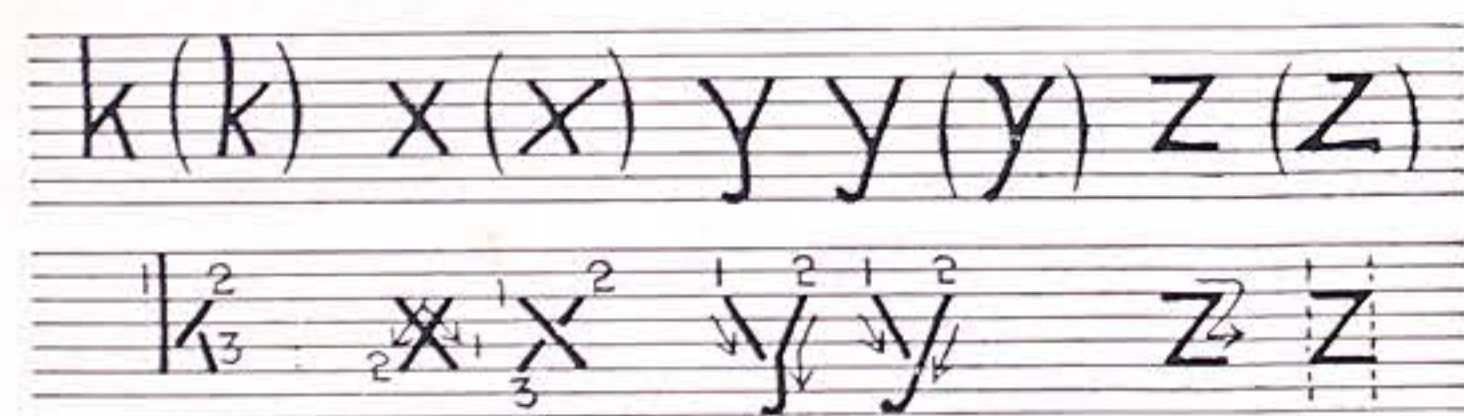

Fig. 25.

The third stroke begins at about the centre of the second one. The letter "x" is constructed with two strokes, making the first one apparently more inclined than necessary for reasons

explained above. When the pen is very full, the second stroke may be made in two parts, as shown, thereby preventing the forming of a clot of ink at the intersection of those two strokes. The upper part of letter "y" forms a perfect "v." The second stroke may either be executed with a slight angle terminating in a vertical direction, or in a perfectly straight inclined line, according to the draftsman's individual taste. Letter "z" is as usual formed in one stroke; its starting point should be vertically above the point of turning into the horizontal.

The ellipses of the letter shown in Fig. 26, are as usual constructed in two strokes, joining the respective

initial and terminal points carefully. The first curve starts in an almost horizontal direction towards the

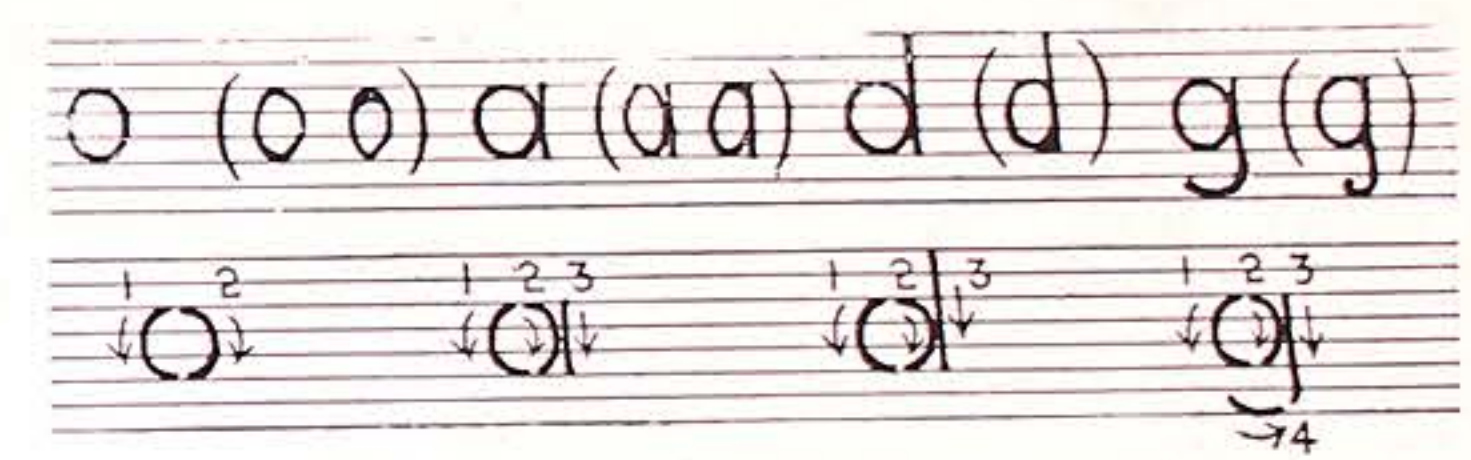

Fig. 26.

left and terminates similarly at the right, thus preventing the forming of a point at the top and bottom junctures. The second (right hand) stroke of the ellipse ought to be made apparently more curved than necessary, as that portion is invariably made too flat by the beginner. The ellipses should be made quite full. The vertical

down-strokes of letters "a," "d" and "g" ought to run tangent to their ellipses so that the thickness of the second curve at the joint of juncture is not increased. The curved portion or the fourth stroke of letter "g" extends to the left almost or nearly the full width of the oval of this letter.

The mode of construction of letters "q," "p" and "b" (Fig. 27) offers no novel features. If the pen, while rounding in the lower part of the curve of letters "p" and "b," should contain too much ink, the curve may be completed by a third stroke, running in an opposite direction, as shown, as in turning into the lower portion of the curve a somewhat greater pressure is involuntarily brought upon the pen, resulting if too full, in a badly proportioned lower end.

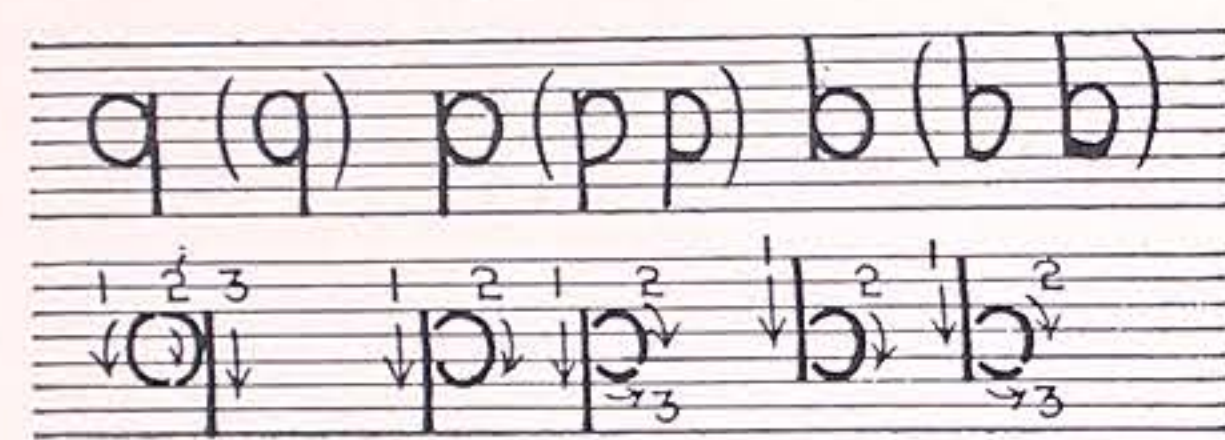

Fig. 27.

Capital Letters.

Upright capitals are, as a rule, 5 spaces high, with the exception of the "Q," the appendix of which ought to reach one space below the base line. These letters

Letters "c" and "s" (Fig. 28) are started with a short curve towards the right; the upper end of letter "c" should be slightly more curved than the lower one; still, the form of the perfect oval should be predominant in this letter. The letter "e" is constructed in three strokes. If, as is sometimes the case, the upper part of letters "c" and "e" should not precisely fill the allotted space, or otherwise they should appear too narrow, a slight flattening of the lower portions of the curve, making those letters appear leaning backward, will help matters and otherwise not at all injure their appearance, as shown. The completed ovals of letter "s" should, as in the inclined one, form a perfect figure "8." If at all uneven, the lower oval should be made more prominent than the upper one.

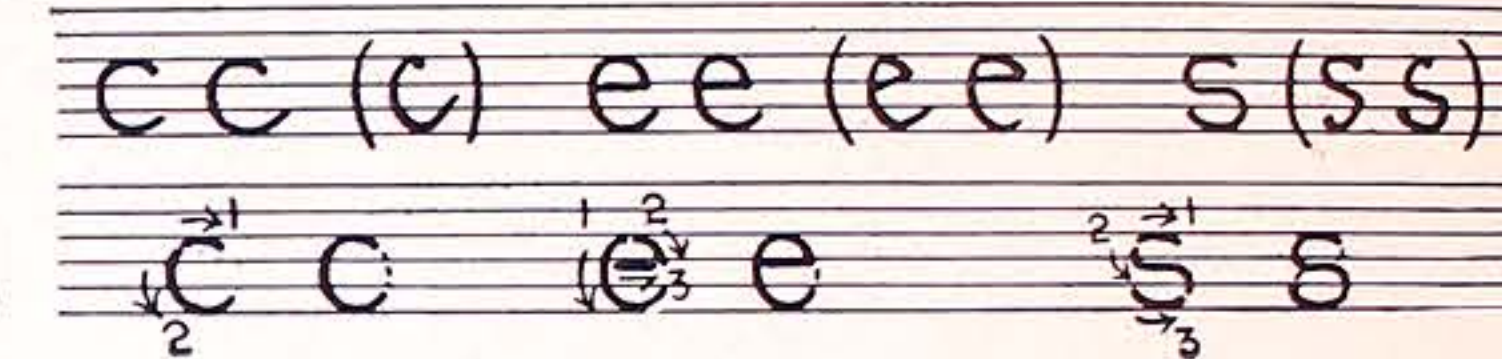

Fig. 28

should be made narrower in proportion than the corresponding lower case letters.

The second stroke of letter "A" (Fig. 29), should

be made rather more inclined than the first one by the beginner. The first strokes of letters "E" and "F" must be made perfectly vertical or leaning backwards, as even the slightest inclination forward in these two letters will be painfully noticeable, especially in the "F." The length of the short third stroke in the "F," is generally depending on the shape of the succeeding

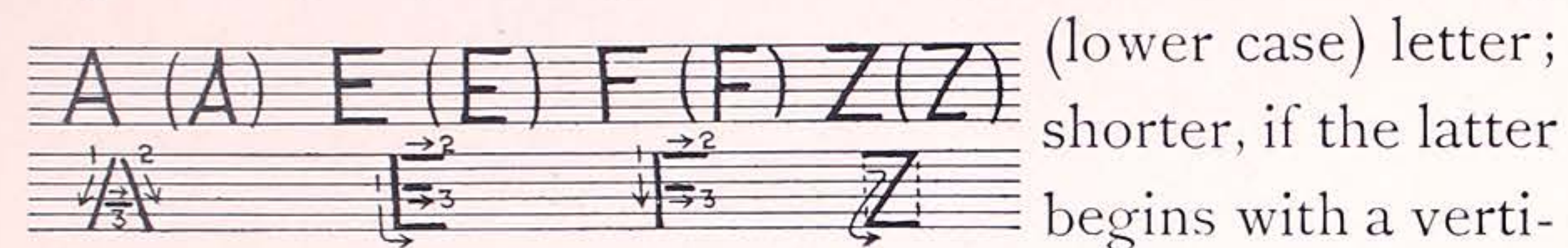

Fig. 29.

(lower case) letter; shorter, if the latter begins with a vertical stroke, longer, if an oval or inclined stroke is to follow. We will not attempt, however, to lay down any definite rule on this point, as the determining factor in each case should be the draftsman's eye and good taste. Letter "Z" is best formed in one stroke, care being taken to make especially the inclined portion perfectly straight.

The letters comprising Fig. 30 are constructed upon nearly the same principles given in the case of the corresponding slanting capital letters. The termination of the last stroke of



Fig. 30.

letter "K" should in a well formed letter be vertically below the initial point of the second stroke. The length of the horizontal portion of the "L" is again, as in the case of the "F," determined by the succeeding (lower case) letter. It is obvious, that by unduly lengthening that portion of the letter, an unproportionally wide space will result between its vertical part and the succeeding letter.

The curved part of letter "J" (Fig. 31) ought to be a well shaped semicircle, beginning and ending not above the middle of the second space. The second and third strokes of letter "M" converge at the second line, and this point should, of course, be at an even distance from the vertical strokes.

To attain this end exactly, some draftsmen will per-



Fig. 31.

haps find it easier to put in the two verticals first and the oblique strokes afterwards, as in the construction of the letter "N." The angles in those two letters should be sharply defined, the strokes forming them ending in a clearly cut, though somewhat blunt point. The second horizontal stroke of letter "T" ought to be evenly balanced upon the main or down-stroke.

The construction of the letters shown in Fig. 32 is chiefly guided by the principle that the rate of inclination of the slanting strokes should be uniform in each

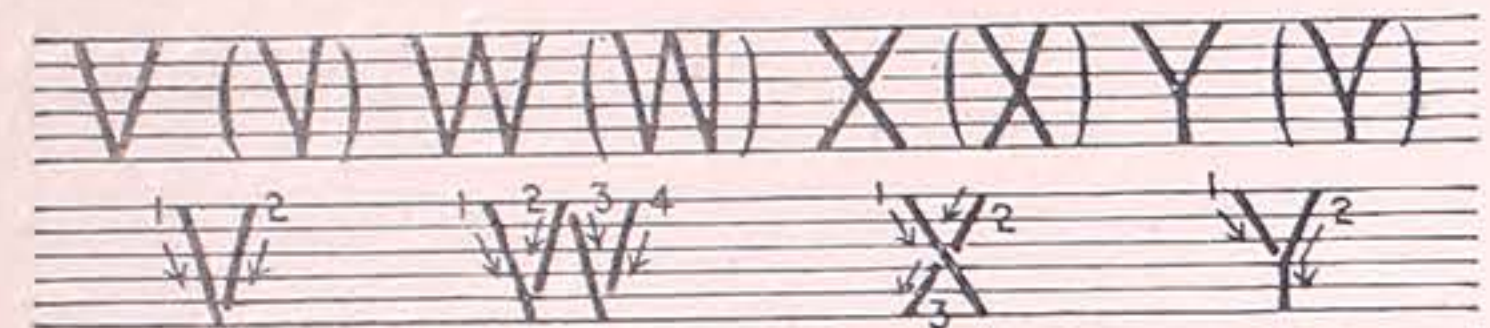

Fig. 32.

letter. In the case of the "V" and "W" care should be taken that only the center lines of the inclined strokes join at the base or top lines of the ruling, thus avoiding two extremes, either the formation of a vertical short end or the reverse, a flattened-out point. This is made apparent in the small illustration, Fig. 32a.

The first and fourth strokes of letter "W" ought theoretically to be made parallel to the second and third;

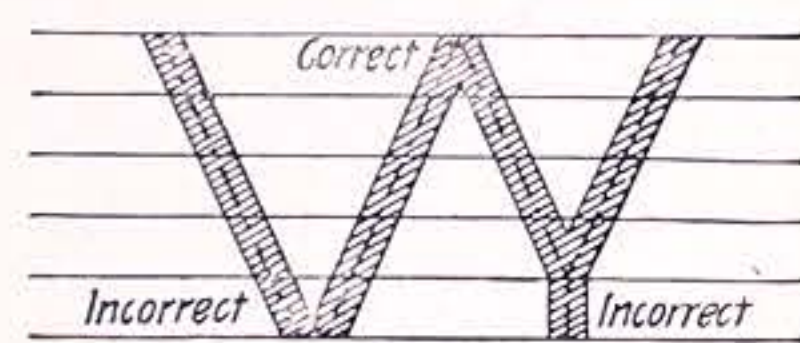

Fig. 32a

but as the latter two strokes are involuntarily made more upright than the first one, the fourth stroke should again be made more slanting to correspond with the first. The reverse mode of procedure would result in a badly shaped letter, as shown in brackets. Letter "X" is usually made in two strokes, or, if preferable, a stop may be made in the second stroke shortly before crossing the first, continuing it on the other side, avoiding thus the

forming of a lump of ink at the point of intersection. The two inclined parts of letter "Y" should join on the top of the second space; from there the second stroke is continued in a vertical direction down to the base line.

Letter "P" (Fig. 33) is constructed in two strokes, the second one beginning at the top of the first, carefully rounding the curve and joining the first



Fig. 33.

stroke again at right angles as a perfectly straight line. The third stroke of letter "B" begins at the point of curve of the second, enclosing a slightly larger area than the second one. The second stroke of letter "D" should begin and terminate in a horizontal direction. If a slight "sagging" should happen in the curve, it ought to be near its lower portion. The rule given for the forming of the second stroke of letter "B" applies also to letter "R;" its third inclined stroke begins at the point of curve of the second. The two vertical strokes of letter "U" are made first; a right hand carefully formed semi-circular curve connects the two.

Letter "C" (Fig. 34) is made with two strokes, and is simply a repetition of the lower case letter, relatively narrower. The second stroke of letter "G" follows the outline of the

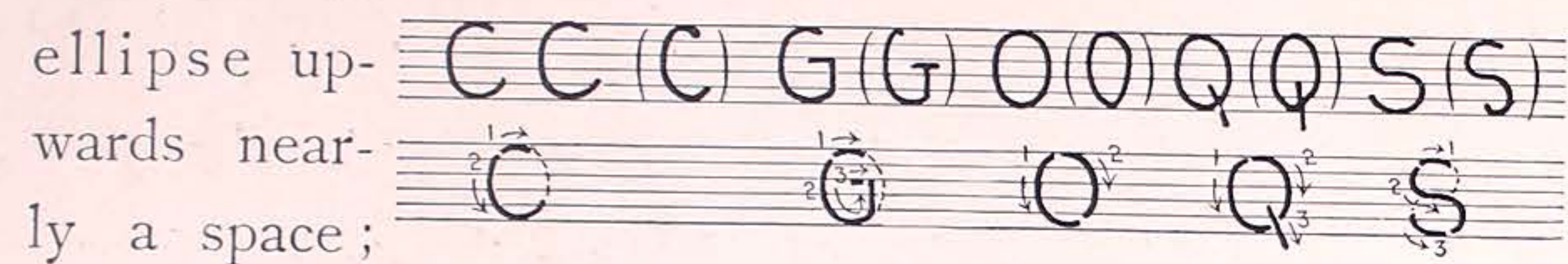

Fig. 34

stop is made and the pen point is carefully pushed upwards in a vertical direction, terminating that stroke as shown. The final horizontal stroke should not be made too short. To those who might find it difficult to exe-

cute the second stroke neatly in the way outlined the suggestion of a separate vertical downward stroke is made. The mode of construction of the ellipses of the "O" and "Q" differ somewhat from that of the lower case letters; the point of juncture is shifted diagonally in order to lessen the chance of a point forming at the top and bottom of the oval. The third stroke of letter "Q" begins as shown, and extends one space below. The second stroke of letter "S" should for a very short space run perfectly horizontal. The rules given for the forming of the lower case letter otherwise apply to this letter also.

Numerals.

Upright numerals ought to be like the inclined ones, five spaces high. Figure "1" may again, if used in proximity with capital letter "I"

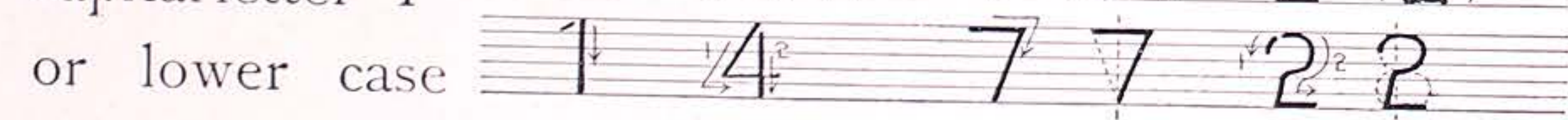

Fig. 35.

shown, whence it assumes a horizontal direction. The rule given above and illustrated by Fig. 32a on the forming of a clear cut angle, applies to the top part of this figure especially. The lower terminal point of numeral "7" should, in a perfectly formed figure, be vertically below the center of the horizontal portion. The upper part of numeral "2" ought to form portion of a flattened oval. The mode of its construction is clearly shown in the illustration, Fig. 35.

Numeral "5" (Fig. 36) begins with a vertical stroke to nearly the middle of the third space; from there the stroke follows the outline of the ellipse, which is to be three spaces high. The middle portion of the second stroke of numeral "6" ought to follow the vertical direction a short distance, as the general tendency in constructing this

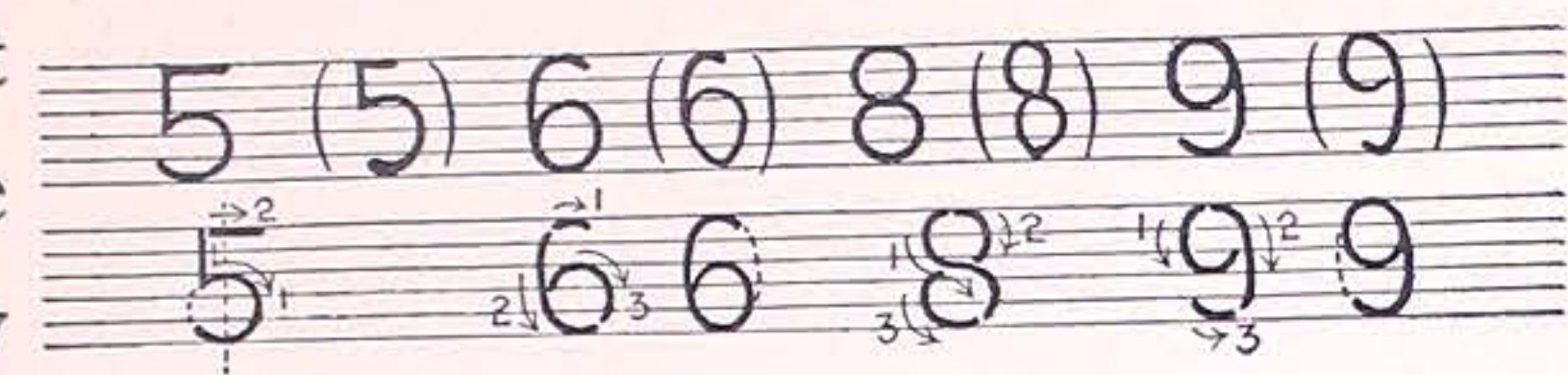

Fig. 36.

figure is to have that part too much curved. The third stroke ought to enclose a perfect ellipse. Numeral "8" is formed in three strokes; its first a well-shaped ogee curve, with its middle portion running very nearly horizontal. The first stroke of numeral "9" ought to

Extended Form of Upright Lettering.

In the following illustration, Fig. 38, the upright lettering is shown in extended form. It will be noticed that for the construction of some of those letters a comparatively greater number of strokes is required. The axes of the ellipses lie in a horizontal direction in every case, and it will be well to shape parts of the curves, composing

be part of a perfect ellipse and comprising as it does, nearly two-thirds of its circumference, is somewhat difficult to construct. The middle portion of the second stroke should for a short distance, run almost vertical.

The upright Roman numerals, Fig. 37,



Fig. 37.

are constructed, analogous to the inclined ones, with upper and lower short horizontal strokes. After explaining the mode of forming of capital letters "V" and "X," nothing new can be said concerning these, except that as a general rule it will be well to make them a trifle narrower in proportion.

them, decidedly flat, sometimes going to the extreme to have the top and bottom parts of the ellipses running perfectly straight for a certain distance.

The complete alphabets of the slanting and upright type are shown in Plate I., together with samples of lettering as used on working drawings. The single

letters, composing a word, should, especially in slanting lettering, be placed as close as possible, so close, in fact,

Sufficient space should be allotted between different words. Of all the theories set forth upon the spacing



Fig. 38.

that they sometimes nearly touch each other. If this principle is followed out at first, the golden middle governing the spacing of letters will soon prevail. The beginner generally spaces his letters too far apart.

of lettering the writer has found that no one really "works" in practice; therefore he would advise the draftsman to depend solely upon his eye in determining the proper space. The spacing of a word for instance,

should be so arranged that, when the drawing is held at some distance, or is looked at with half closed eyes, no unusually large white space appears between letters, as shown for example in Fig. 39a, which, an actual specimen of printed type, demonstrates the fallacy of one of

ONLY STANDARD.

ONLY STANDARD.

a.
b.
(Corrected.)
Fig. 39.

the theories upon spacing, and should appear corrected as in Fig. 39b, showing, as it were, a more even tone of coloring.

In expressing fractions, the accepted custom is to place a horizontal dash between numerator and denominator, excepting the instance when numeral "4" happen to be the latter, in which case, for obvious reasons, a slanting dash is employed. The several lines of lettering composing a sentence, for instance, should be placed rather close.

FREEHAND LETTERING APPLIED TO WORKING DRAWINGS.

Lettering as applied to working drawings, should be bold, clear and uniform in size, with the exception of the sub-captions, which may be a trifle larger. Diminutive and cramped lettering on a drawing will never look well. If possible, the lettering should be kept distinctly by itself and never be allowed to run across lines. If some words can not be put on the object itself, which they are intended to describe, they should be boldly placed out-

side, and a dotted reference line with arrow head point-

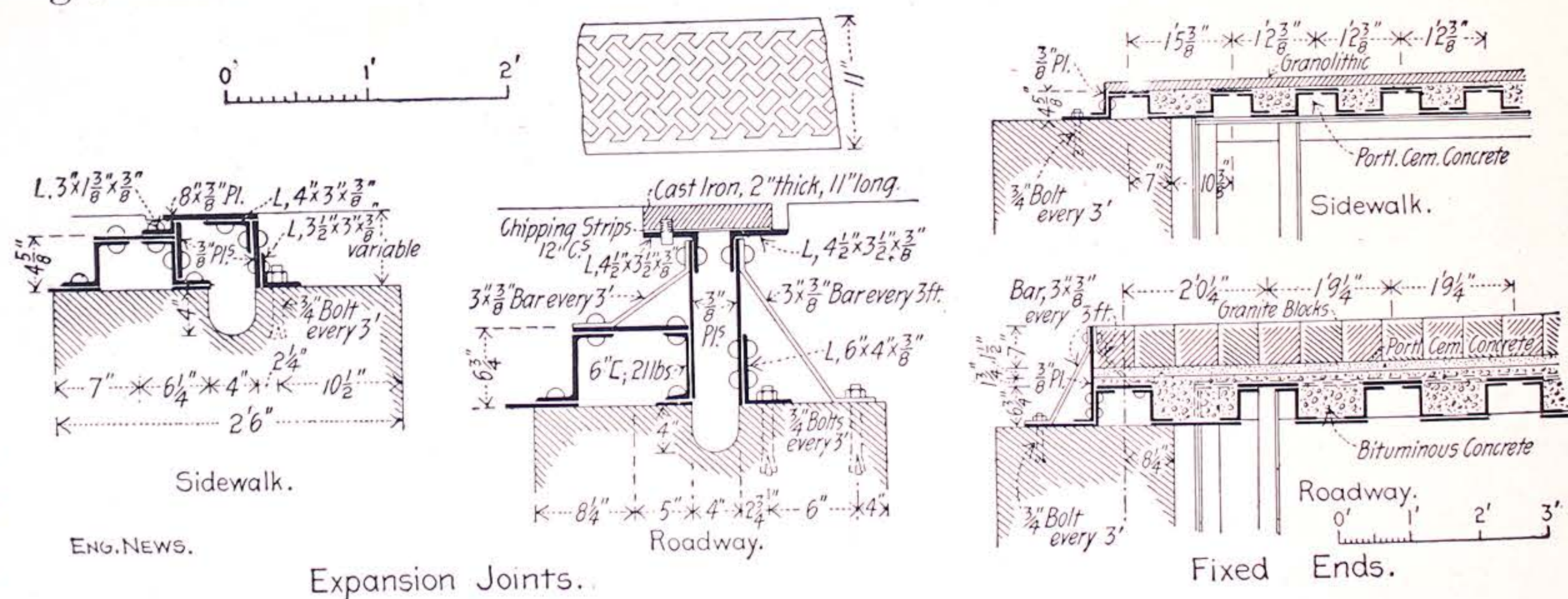

Fig. 40.

ing to the subject attached, as shown especially in Figs. 40, 41 and 42. The lettering should be placed so as to read from the base and right hand side of the sheet, that is to say, lettering running at an angle of 90° to the base line should be made to read from the right hand side, if at a greater angle, its base should be reversed in such a way that it can be read from the lower left hand corner; if the angle be smaller, one should then be enabled to read it from the lower right hand corner, as Fig. 44 demonstrates.

Dimensions should be placed between, not on top of

dimension lines, and an appropriate space left open while drawing those. If the space allotted for a dimension

is too small to place the same comfortably between arrow heads, the figures should be written outside, parallel to dimension line, and reference line used. Arrow heads should be bold, with even sides, the two strokes composing them tapering in thickness from the point; "lop-sided" ones should be avoided.

The length of the arrow heads depends upon the size of the dimension numerals, which are to go between them; at any rate,

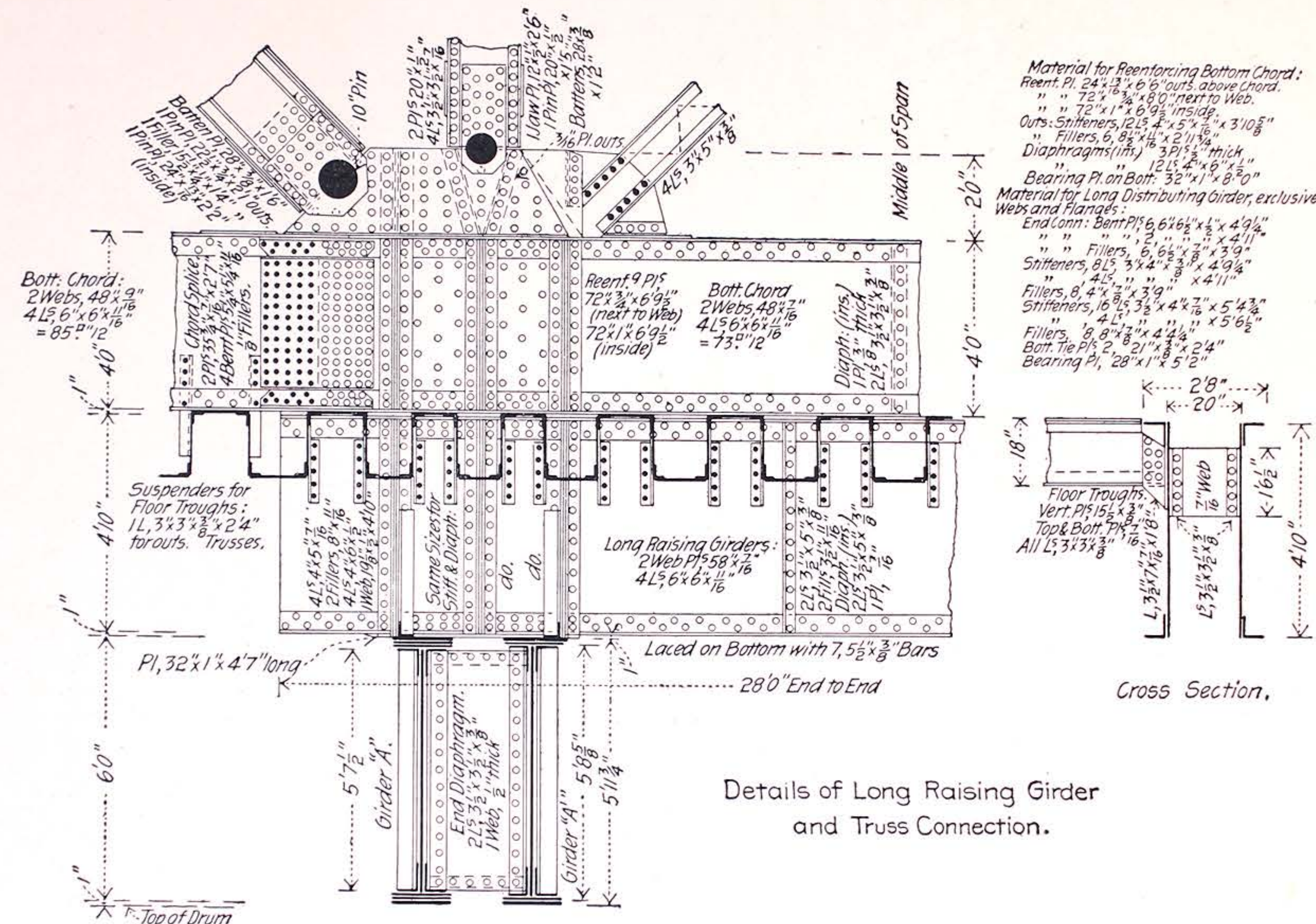

Fig. 41.

the numerals themselves should stand out free and not touch the former. Where the space does not permit this, the reversed arrow heads may be used, so as to leave a clear space between them, as shown, for instance, at left of Fig. 40, in second row of dimensions from below. In the same figure the relative size of upright

an inset sheet in "Engineering News" and yet shows the lettering of the strain-sheet legible, sharp and clean cut, even under a magnifying glass. The pin points, as shown, are also made prominent by using upright reference letters. Similar prominence may be given, for instance, to portions of a building, as shown in Plate XIV

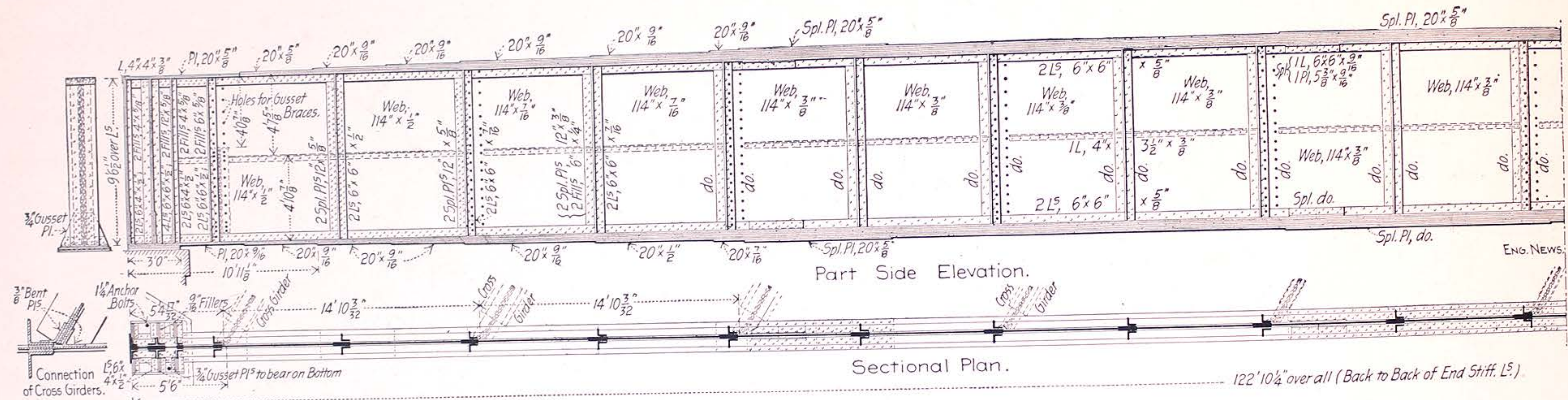

Fig. 42.

lettering, as used for captions and sub-captions is shown. In Fig. 44 and on Plate III, upright lettering is also employed to denote the strains for the respective members, in order to have same appear distinctly different from ordinary dimensions or descriptive matter. This plate has been considerably reduced in size from a drawing for

on plan of station building. Notes referring to drawings should run parallel to base of sheet and be used as "fillers."

In Fig. 43 and Plate II, lettering as used on sketch maps is shown. Here four distinctive styles, composed of the two alphabets above described, are employed.

The w
physica
mounta
letters
case"
in "ca
case"
tering
countie
or cit
caps,"
These
all, of
ject to
modifi
casione
lines,
etc., m
Plate
relatin
paralle
lines i
ticable

The writer recommends, in such a case, to have the physical features of a map, such as creeks, rivers, lakes, mountains, bays, inlets, denoted by "all cap" slanting letters; proposed engineering works in "caps and lower case" of the same type; villages, railway lines, stations in "cap and lower case" upright lettering; finally, counties, townships or cities in "all caps," upright. These rules are all, of course, subject to more or less modification, as occasionally contour lines, soundings, etc., may also be designated in small upright numerals. Plate II illustrates the above said very well. Letters relating to rivers and railway lines should be placed parallel to those objects. Otherwise, lettering in straight lines is resorted to. If this should, however, be impracticable, lettering in neat curves is used.

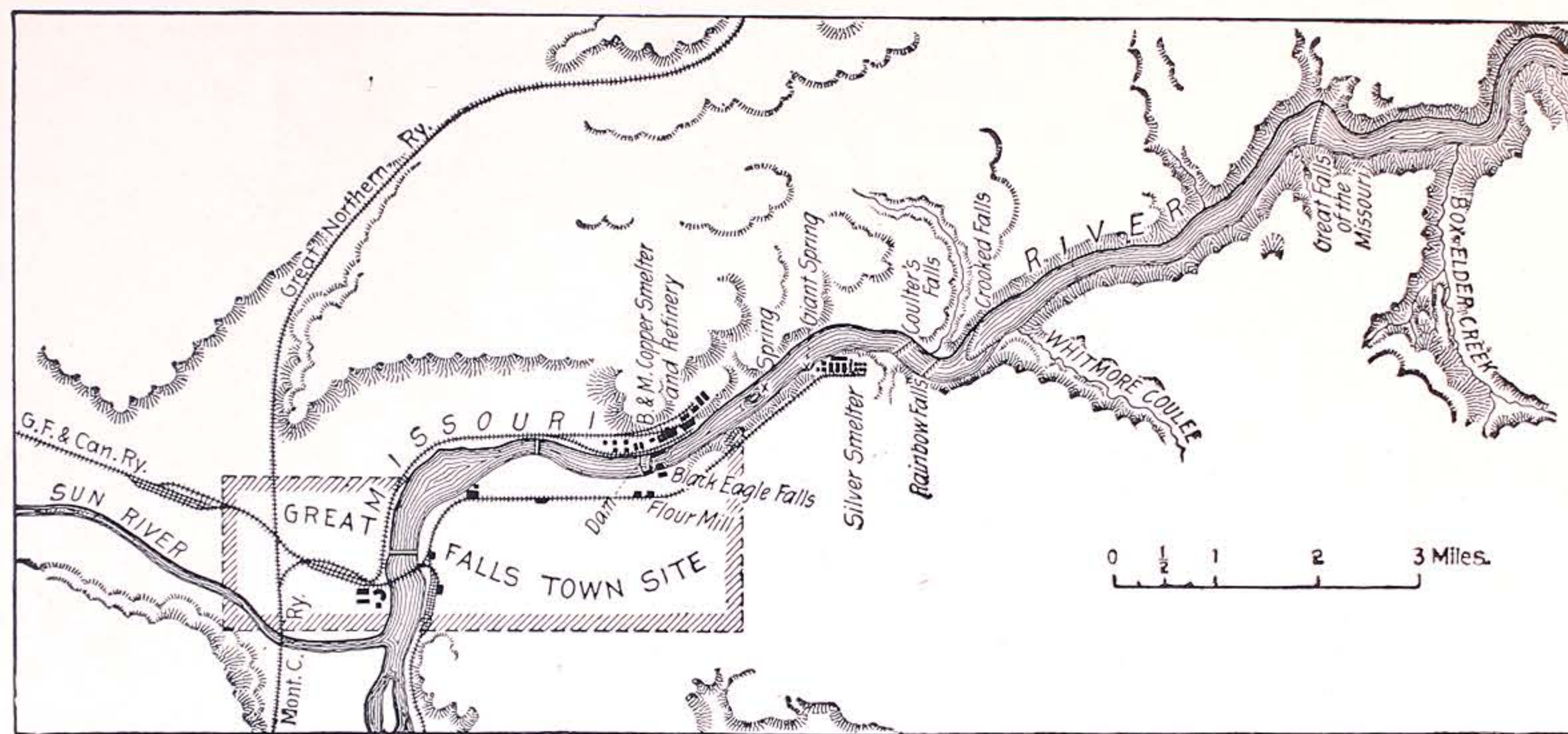

Fig. 43.

Profiles of railway lines, etc., may be treated in a similar manner; the margin figures denoting vertical and horizontal scales, should, however, be placed in uprights and be written outside, not upon the lines of the scale. The use of the four distinct types of lettering will at

once allow an easier reading of the profile. A good example of this kind is given in Fig. 45.

The arrangement of margin figures here will permit the approximate elevation of any desired point easily to be ascer-

tained by laying a rule across the vertical scales, its upper edge touching the point in question. In Fig. 46, the general style of lettering a diagram is shown. The margin figures again are uprights, set opposite, not upon the lines, which they are to designate. The lettering of the curves, being of a descriptive character, is

done in the slanting type. Since this lettering has to run across the ordinates and abscissae of the diagram, great care has to be exercised to keep same open and clear, especially avoiding filled in corners.

Examples of simple and also slightly more elaborate meridians and scales are given on Plate XIV. All of the former are easy to construct and will look neat on any

well finished map. The lower two scales are best adapted for map work, although the upper one, intended for ordinary working drawings, can also very well be used for that purpose. In constructing the simpler type of scales it is advisable to employ four different heights of graduation lines, a method which will materially increase its clearness.

VARIOUS FREEHAND ALPHABETS.

The principles of construction of the shaded inclined (Italic) lettering, shown on Plate IV, which is occasionally used on working drawings and maps, are practically the same as given for the ordinary (Gothic) slanting lettering. The relative height of letters and inclination of down-stroke remain unchanged. A fairly fine pointed rather flexible pen should be used, such as Gillott's No. 303 or No. 290 (Gillott's lithographic pen). The lower case letters are very much like common English shaded script. The shading is produced by an even pressure exerted upon the pen, which in turning into curves, is gradually released at the proper moment. In shading letters "S" and numerals "2," "7" and "8"

the pen has to outline and shade the curves at the same time, necessitating a slight turning motion of the holder, to the beginner a somewhat delicate operation at first. It will be noticed, that every second row in the upper portion of this plate is devoted to demonstrating the proper method of forming each letter and the sequence of strokes. Italic lettering, in order to look well, requires a considerably wider spacing than the ordinary slanting lettering, the hair line upstrokes in most of the lower case letters adding to their width. After all that has been said about slanting lettering in general, no trouble will be experienced in constructing these letters satisfactorily.

When
does no
Gothic
droppin
ible.
The t
is in fa

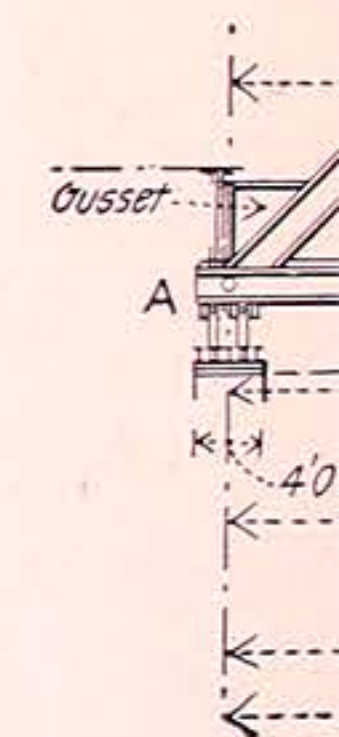

freehan
well wh

When reduced considerably, Italic lettering, as a rule, does not show up so well as the same size of the slanting Gothic type described before, the light lines in that case dropping out, thus leaving only the shaded portions visible.

The type of lettering shown in lower part of Plate IV, is in fact only a modification of the ordinary upright

shown on Plate V. As is known to every draftsman, a lump of ink is apt to form at the end of a straight stroke,

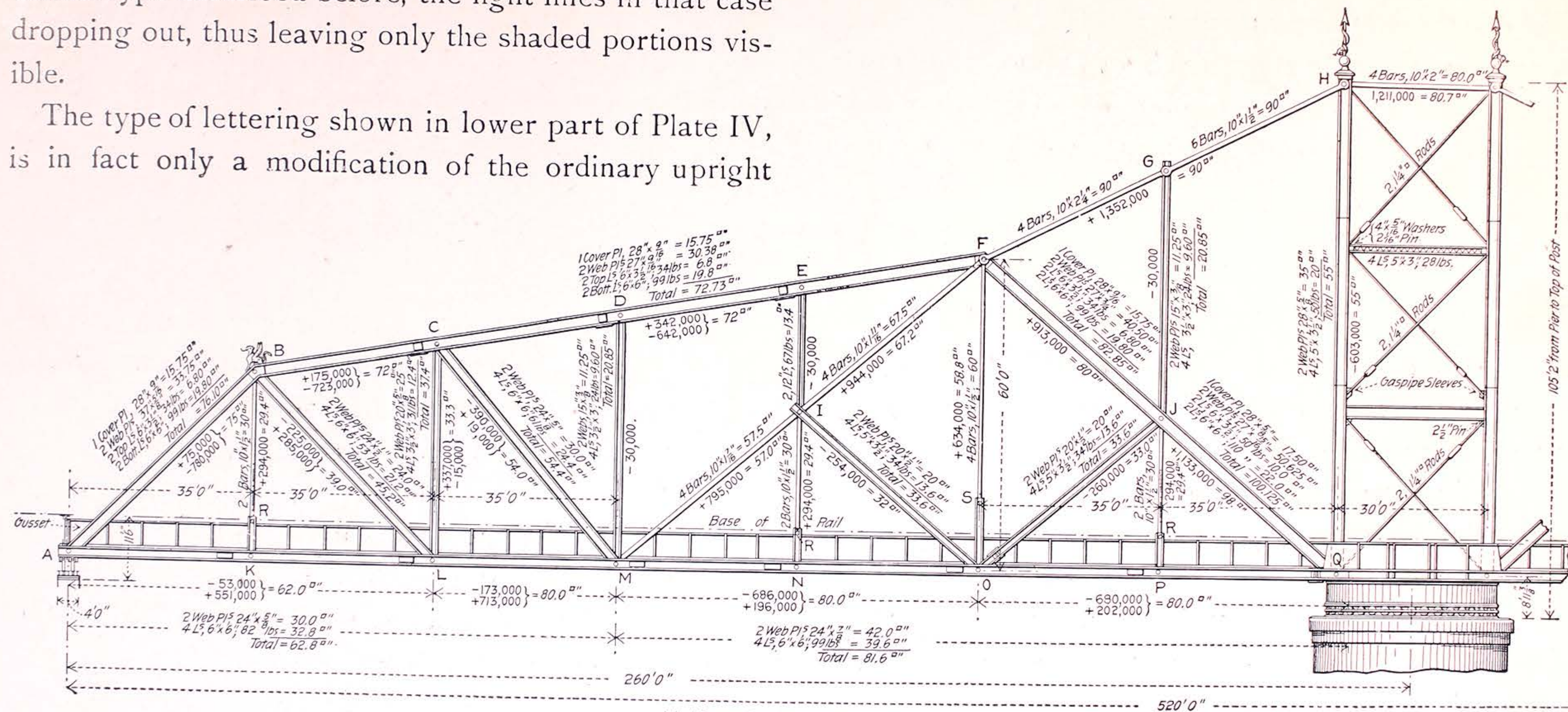

Half Side Elevation.
Fig. 44.

freehand lettering, and used as a part of title looks very well when used with the black faced Gothic lettering,

when the pen is fairly full. This propensity of the ink is made use of in constructing this type of lettering and

the flow of ink thus diverted. The relative number of strokes remains the same, as with the ordinary upright style. A few modifications are introduced in the shape

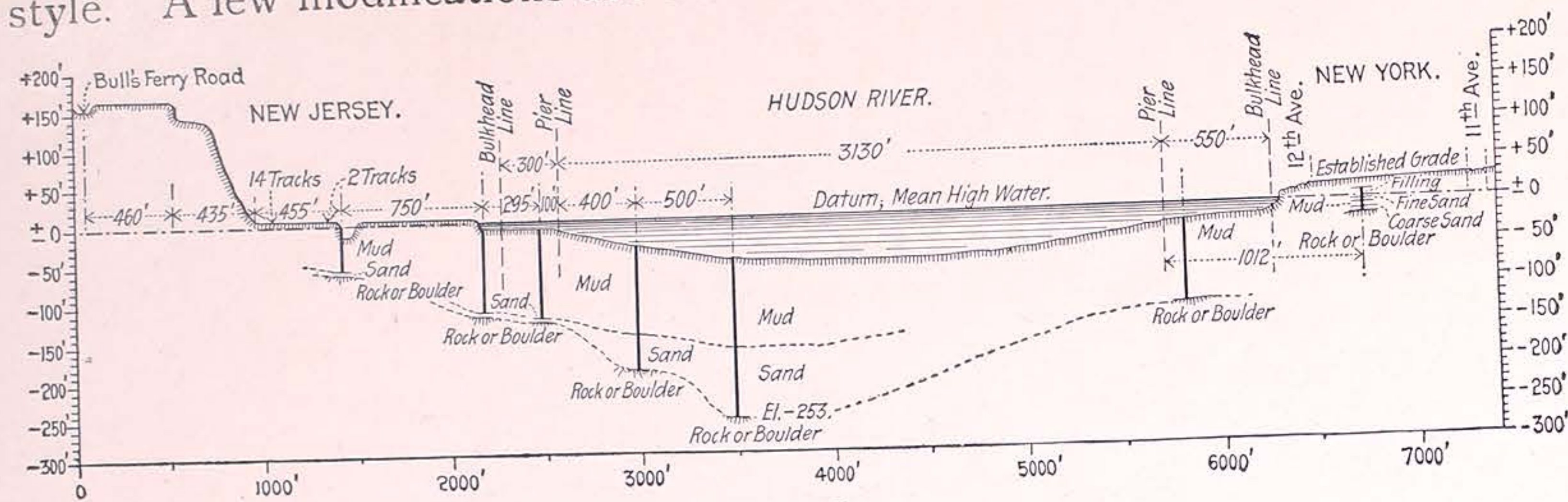

Fig. 45.

of lower case "a" and "g." This lettering is best produced with a ball point pen, insuring a stroke of almost uniform strength. As a precaution, it may be said that the pen should never be too full while making this type of lettering.

Plates V to VII inclusive, contain Freehand Lettering suitable for main titles, which may easily be constructed by dividing the space to be lettered into squares and sketching in the letters in outline afterwards, as shown; on tracing linen, cross-section paper may of course be used for this purpose. A draftsman able to satisfactorily construct the upright lettering, the principles

of which have been exhaustively explained in the foregoing, will experience no trouble whatever in sketching these letters in good shape. As shown, the relative height of lower case and capital letters remains unchanged; the width of the stem of the capital may be taken as 4-5, in some cases 7-8, that of the lower case letters as 3-5 the width of a square.

On Plate V suggestions are made as to several methods of shading these letters, although, as a rule, they look very well without it.

When this kind of lettering is desired to be of medium or small size, it can neatly and

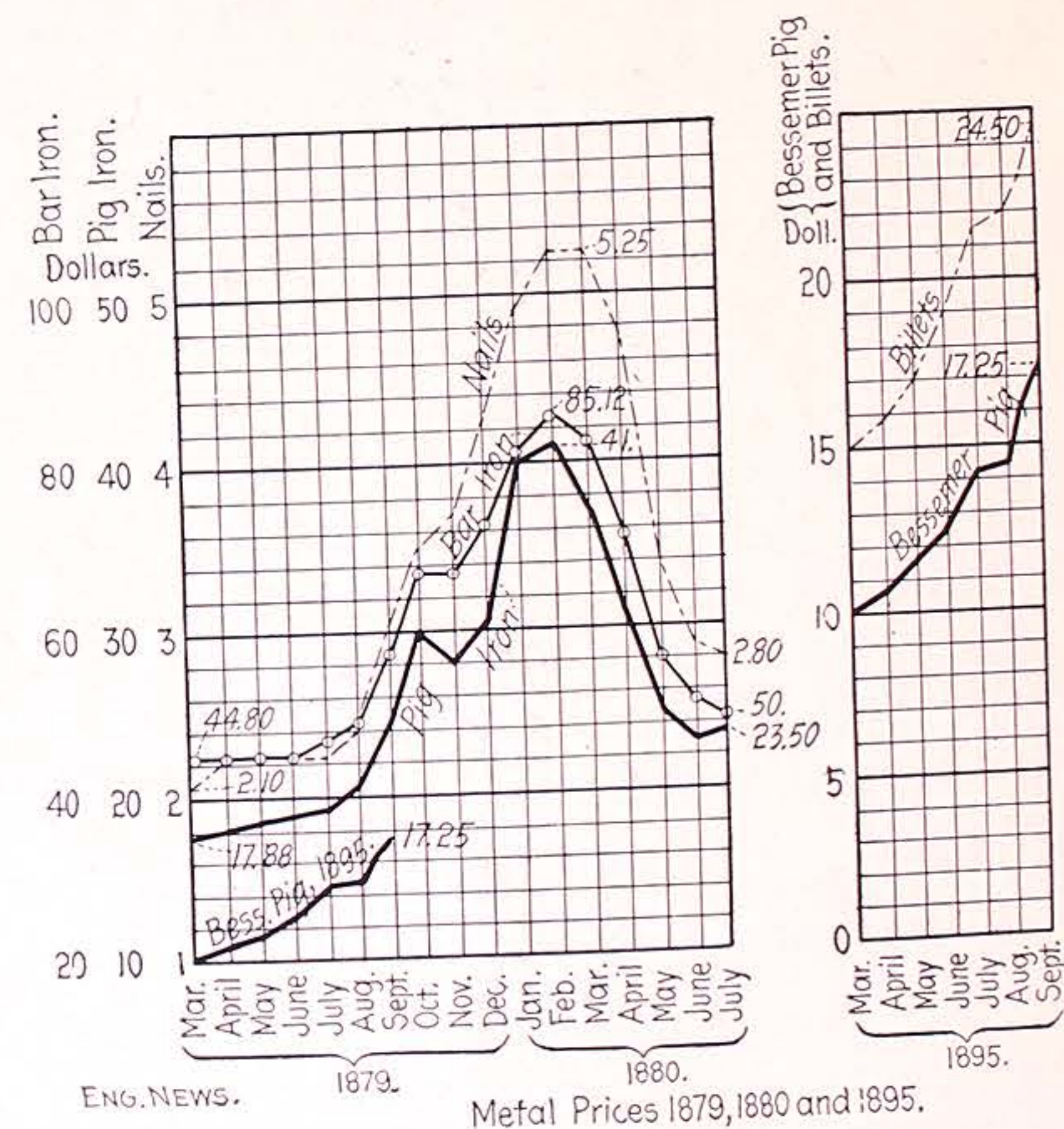

Fig. 46.

expedit
47a :
nibbed
stroke
Gothic
the exc
strokes
the top
letters,
corners
known
draw h
ferable
draftsm
him. I
more o
his eye
the lett
howeve
highly

expeditiously be constructed in the way shown by Fig. 47a: Throw in the stems of the letters with a broad nibbed pen, insuring a bold stroke analogous to ordinary Gothic upright lettering, with the exception of the horizontal strokes, which, together with the tops and bottoms of the letters, rule in, and fill in the corners freehand, as shown enlarged in 47b. As is well known, short freehand strokes are somewhat difficult to draw horizontally, therefore this method is certainly preferable to that of turning the paper, so as to permit the draftsman to draw these strokes in the direction towards him. If, as the case may be, the draftsman should desire more ornamental letters, he will be able, by the aid of his eye, and the exercise of some originality, to devolve the letters desired out of the types given. It should, however, be borne in mind, that a title, composed of highly ornamented letters, does not atone for any poorly

(Original) WAYNE
 (Spurred Gothic.) WAYNE
 (Plain Gothic.) WAYNE

Fig. 47a.

drawn and lettered sheet to which it may be attached, but on the other hand, a simple title, constructed of well executed letters of reasonable size, with the several lines composing it, centered, will make an ample heading for any well executed drawing, and conform in style with the subject represented. The draftsman is occasionally called upon to employ the



Fig. 47b.

Greek Alphabet

in his work. There seems to be a lack of uniformity in the construction and shaping of these letters, so that at times the "alpha" cannot be distinguished from lower case "a," or the "gamma" from the "y," etc. Therefore a plate (VIII) representing the principles of construction of the slanting Greek letters, analogous to the Italian Script, shown upon a preceding plate, has been added. Remember, these letters are all shaded characters and must therefore be drawn with a flexible, well pointed pen.

LETTERING OF TITLES.

On Plates XI and XII and the accompanying text figures, reduced specimens of freehand titles are given,

*Bridge #720 Big Run, Evansville, Arizona.
M. K. and T. RY. MIDDLE DIV.
3 Spans, Single Track, Through 175'-0" c.c. End Pins.*

TOP CHORDS AND END POSTS.
Scale 3/4" = 1 ft.

AMERICAN BRIDGE CO.,
EDGEMOOR PLANT.

A. B. Co. Contr. No. 232 In Charge of Wilson
Made by J.C. Date 9/25/00 Rev. 9/30
Checked by E.K. Date 9/27/00 Rev. _____

ORDER NO. K230^a SHEET NO. 12

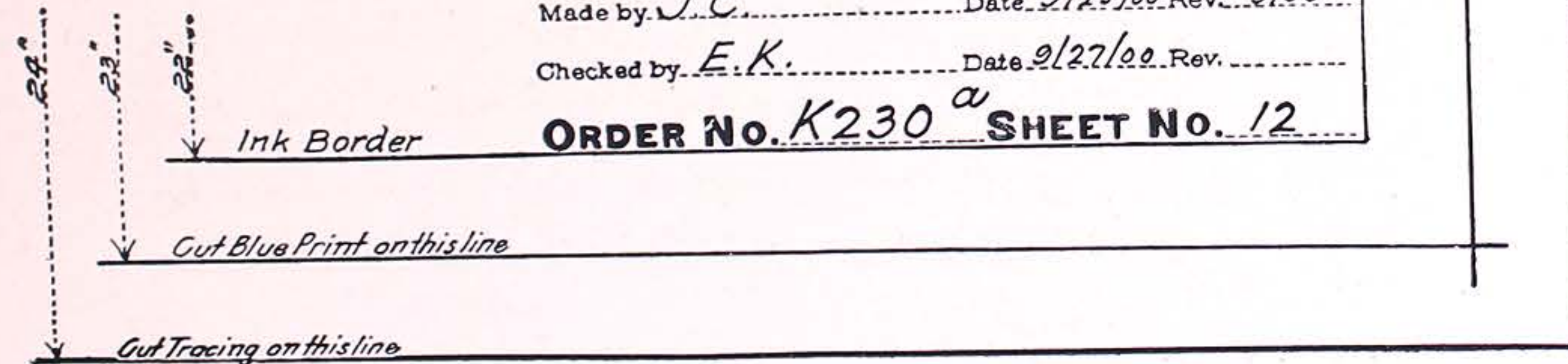

Fig. 48.

and pains have been taken to present, as much as pos-

sible, different types of easily formed and fairly well balanced titles, such as could be selected during the daily routine work in the drafting office of a technical journal. These samples, as given here, represent reductions from originals which range in size from one-half to nearly one-fifth linear measure.

These specimens exhibited on those two plates show more or less clearly that the prominence which is to be given to different portions of a title depends upon the relative importance of the lines. The draftsman is generally given considerable latitude in regard to this matter. The title given under Fig. 48 is one of the standard arrangements of the concern named and shows good points. The lower part, as noticed, is stamped on the drawing, and the blanks are subsequently filled in by hand.

A style of title seldom used nowadays is that shown in Fig. 49. The letters are arranged in curved lines and an ornamental, flourished effect is

sought
scheme
A few
be added
systemat
location
different
equal to
pencil o
a strip p

Gen
G

its edge
The lett
A spa
therefor
letters r

sought after. Where such is desirable, the general scheme is a fairly satisfactory one.

A few words in regard to centering of titles may here be added. A title should in nearly all cases be arranged systematically about a vertical center line. After the location of this line and the height and spacing of the different lines of letters have been determined, the spaces equal to the width of the letters can be marked off with pencil on the edge of a strip of paper and the center of a strip placed on the vertical center line of the title, with

General Plan
OF
Gravity Outlet Sewer
Salt Lake City
SCALE OF
1/2 MILE TO 1000
AND INDEX TO MAP

IN — SHEETS ATTACHED

Fig. 49.

its edge just below the line of letters to be sketched. The letters can then be penciled in very readily.

A space between words counts as a letter in spacing, therefore, a line containing three words of 7, 3 and 6 letters represents 18 divisions, so that 9 divisions, or the

first word, one space and one letter of the second word are to come to the left of the center line, and the remainder of the line to the right. If, after all, the spacing of a line of letters needs readjustment after the letters are penciled in, the draftsman may easily rectify the matter by going over that line again, working first to the left and then to the right of center. More complete instructions with graphic references are presented on plates IX and X, where the actual procedure of laying out and properly arranging various titles is illustrated. These two plates, as noted, are practically self-explanatory, full instructions being given with each.

In Fig. 50, an actual facsimile of a title once met with is exhibited. It explains in short how

not to do it, and shows the draftsman's lack of practice in freehand work, while relying solely upon his skill with bow pen and ruling pen.

Sheet No. 2
NO. 16
END AND SECTIONAL VIEW
OF
EUREKA DRIERS
LONGITUDINAL SECTION

Fig. 50.

Average { Ultimate Strength-----
 Elastic Limit-----
 Elongation in 2"-----
 Reduction of Area-----

$K\gamma$ is the Factor to Reduce Reading to Equivalent Values for Sp. Gr.=1.

$$K\gamma = \frac{\gamma_s - \gamma_m}{\gamma_s - 1}$$

γ_s = Sp. Gr. of Sphere, or grams per cc.
 γ_m = Sp. Gr. of Liquid, or grams per cc.

Legend.

d = Diameter of Bore of Tube, cm.

ω = Velocity of Flow, cm. per sec.

γ = Grams per cc. of Liquid.

η = Absolute Viscosity, dynes per sq. cm.

L = Length of Tube, cm.

In Fig. 4, $l = 23'6" = 282"$; $d = 30.5$; $k \frac{l^2}{d} = 278$.

In Figs. 5 to 8 incl., $l = 144"$; $d = 10"$; $k \frac{l^2}{d} = 221$.

All Specimens Air-Chilled from 1000°C., Reheated to 770°C. and Quenched in Oil, then Drawn for $\frac{1}{2}$ Hour at Temperatures Shown Below.

Number of Blows without Fracture
Maximum Elongation in 1"
Total Elongation in 6"
Permanent Set
Elongation after First Blow
Permanent Set " " "

Fig. 51.

In order that a drawing may be satisfactory, it is essential that the lettering be neatly executed. The appearance of the best drawing is spoiled by poor lettering. In practice it is necessary that a draftsman shall letter not only well, but with reasonable rapidity; hence it is important for the prospective engineer to acquire facility in free-hand lettering at as early a period in his preparatory course as possible. There is but one way in which this can be accomplished, that is, by careful, persevering and long continued practice.

The first aim should be to form the individual letters well and to make their size and slope, as well as the thickness of the individual lines, as nearly uniform as possible without the aid of any mechanical means whatever. Speed will follow in due course. Each succeeding exercise should indicate a well defined improvement on the preceding one. Unless there is a perceptible improvement the time devoted to the work is little better than wasted.

This latter statement can hardly be sufficiently emphasized, and should be borne in mind by the student while engaged on this work.

Fig. 52.

In Figs. 51 and 52 two practice sheets are presented, which might with great profit be traced bodily by the student. As noted, Fig. 51 shows notations of various sizes taken from different curve sheets, which were prepared by the writer for one of our great Engineering Societies. While copying these two sheets, pencil-guide lines should invariably be employed.

The writer would not consider this work complete

without giving passing notice to

Round Writing,

the principles of which are shown on Plate XIII. For the production of this kind of lettering regular round writing pens are used, although very satisfactory lettering of this type can be produced with goose-quills cut by the draftsman, and the writer even yet prefers the latter.

The
be ma
or pap
rule, n
ish onc
tracing
rubbin
materi
ration.
with th
part to
of the
colore
the eff
withou
erasur
be app
Letter
fine lin

LETTERING FOR PHOTO-REPRODUCTION.

The lettering and drawing for reduction purposes may be made on any quality of drawing paper, tracing linen or paper. Yellowish tinted papers however, will as a rule, not give as good results as the pure white or blueish ones. In order to insure good, unbroken lines on tracing cloth the writer would recommend the thorough rubbing of the surface with pumice powder. The other materials mentioned, of course, require no special preparation. Erasures on tracing cloth are also best made with the same agent; the powder is sprinkled upon the part to be erased, and a little brisk rubbing with the end of the finger or a hard rubber, while replacing the discolored pumice with fresh powder, will thoroughly clean the effected surface, which may be lettered over again without danger of the ink spreading. Where, however, erasures have otherwise been made, Chinese white may be applied with a soft brush over the discolored parts. Letters and lines must be made perfectly black; if very fine lines are used on a drawing, they will still reproduce

at considerable reduction, provided each is formed by a solid ridge of ink.

A good standard to adopt for lettering for reproduction is to have the smaller lower case letters, such as "a," "e," etc., reduce to not less than one millimeter (slightly more than $\frac{1}{32}$ in.) in height; therefore, if a drawing is to be reduced three-fourths, (i. e., to one-fourth its original length) make those letters 4 times

Freehand Lettering. that height or 4 millimeters (about $\frac{5}{32}$ in.) high with the strength of body in proportion;

the height of the capitals and numerals must be in accordance. A drawing to be reduced to one half size (one-half its length) has to contain lettering just twice the standard given above. The lettering on draw-



Fig. 53a.

ORIGINAL FOR THREE-FOURTHS REDUCTIONS.

ings to be reduced to a size about halfway between three-fourths and two-thirds reduction, should be made

Freehand Lettering.



Fig. 53b.

ORIGIN L FOR REPRODUCTION BETWEEN ONE-HALF AND TWO-THIRDS.

The two illustrations shown on Plate XIV (details of rail joint and section of reservoir) have been reproduced from originals five and four times their respective sizes. Although the draftsman is supposed to know the exact rate of reduction, the directions to the engravers are better given in inches or fractions thereof, placed in pencil underneath; they are for our purposes reproduced on Fig. 53a and b, but would, of course, not be reproduced by the engraver ordinarily.

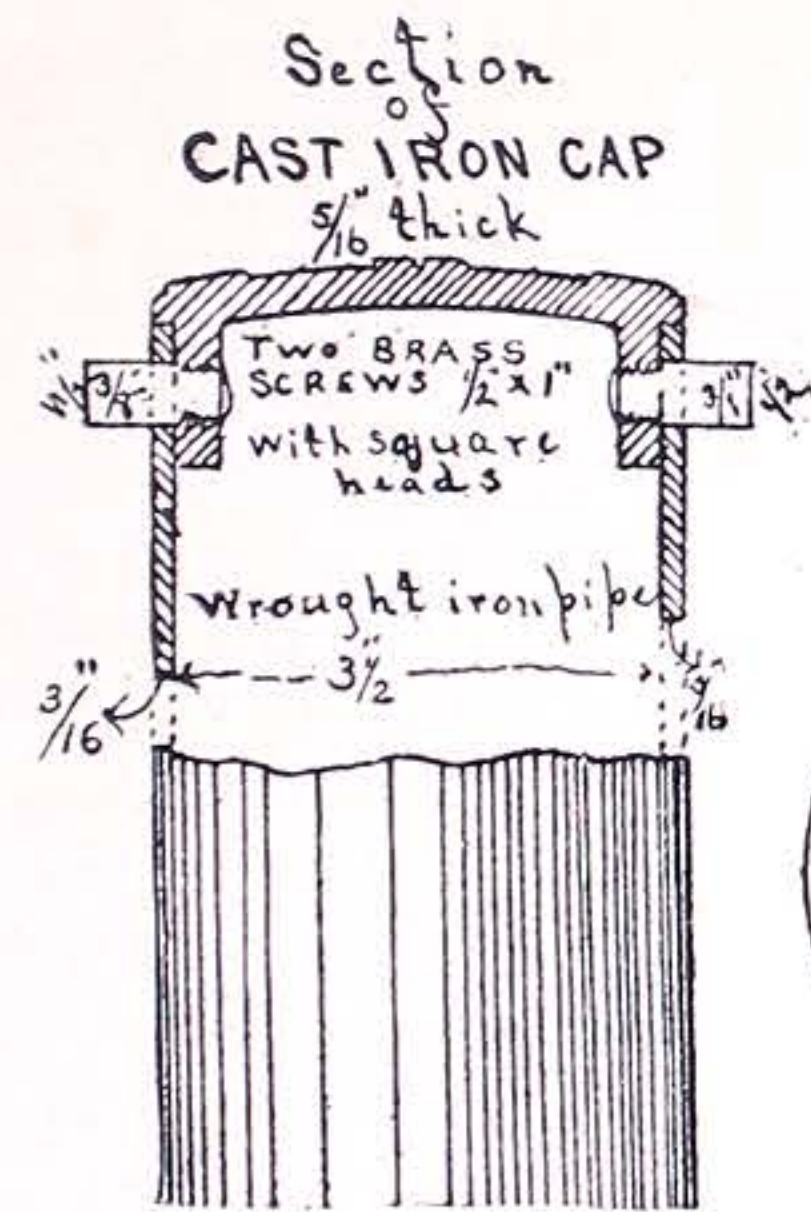

Fig. 54a.

Note:—The top of cap will be slightly oval and the central square, triangle, and circle will be raised about 1/16 above the lettering.



A drawing should never be reduced at a lesser rate than to three-fifths of its original length. What may be called a good average reduction is one-third its condensed length on drawings for reduction purposes a proper safeguard to adopt is to exaggerate somewhat the width of ovals or small loops, such as for instance of the letter "e," to guard against the "filling in" of those parts. A close study of the three types of lettering given on Fig. 1 of this work, which tend to illustrate the same principle, will also be useful. The reason for giving a limit of reduction (i. e., one millimeter height for smaller lower case letters) and the employment of gothic letters of uniform strength, is made evident by referring to the illustrations, Fig. 54a,

Freehand Lettering.

Fig. 53c.

REPRODUCTION FROM EITHER OF THE ABOVE ORIGINALS.

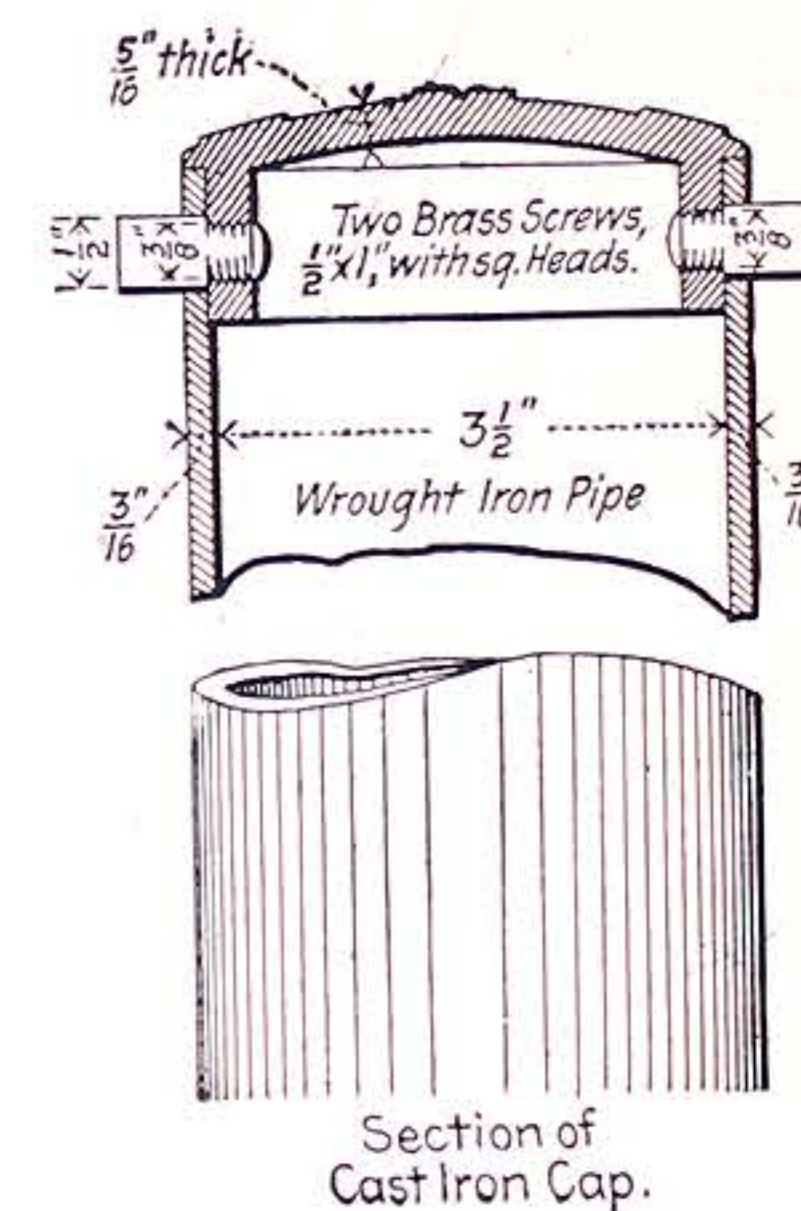

Fig. 54b.

Note:—The Top of Cap will be slightly oval, and the central square, triangle, and circle will be raised about 1/16 above the lettering.



Top of Cap.

which
someti
reduce

The
duced
ductio
to sho
ble, fo
of an
be cle
appea

The

which presents an example of engraving, such as is sometimes indulged in, and Fig. 54*b*, redrawn and reduced to some scale.

The strength of the lines of a drawing to be reproduced depends of course altogether upon the rate of reduction. For larger reductions it will be quite essential to show as much of a white space between lines as possible, for instance such as designates the thickness of flange of an I-beam in elevation. The work should in all cases be clear and open, and this detail, immaterial as it may appear, not be overlooked.

The processes of photo-reproduction ordinarily em-

ployed are the photo-lithographic and zinc etching process. Both require a similar grade of preparation of the drawing. The writer uses on such drawing the waterproof ink, which is perhaps blacker than the ordinary kind and possesses more body. Any kind of black drawing ink, however, is suitable for the purpose; well rubbed stick India ink will permit of very fine black lines. The main objection to the use of ordinary inks, however, is their liability of blurring, when handled, or the ink mixing with the Chinese white, rendering the application of the color sometimes very difficult.

abcdefghijklmnopqrstuvwxyz., 12345678910. 1894.
A B C D E F G H I J K L M N O P Q R S T U V W X Y Z. Ordinary Type.
I II III IV V VI VII VIII IX X. Details of Cross Framing. CROSS SECTION OF GIRDER.
Extended Lettering. LONGITUDINAL SECTION. &
Compressed Type. INTERSTATE BRIDGE. Spur Wheel, 32" Diam., 7" Face, $3\frac{9}{64}$ " Pitch, 32 Teeth, 5.2 Rev's. $9\frac{3}{4}$ " turned Pin, 3'6" long.

abcdefghijklmnopqrstuvwxyz. 12345678910. $13\frac{7}{8}$ " ; $\frac{15}{16}$ " ; $\frac{3}{4}$ ".
A B C D E F G H I J K L M N O P Q R S T U V W X Y Z. I II III IV V VI VII VIII IX X.
Ordinary Lettering. I Beam. Eye Bar. $4L^S, 6" \times 6" \times \frac{11}{16}" = 85.12''$ 2 Webs, $48" \times \frac{7}{16}"$
Extended. 95 Ft. Span. End View. etc.
Compressed. 1, 12" C, -lbs. per yd. NEW YORK CENTRAL. $2\frac{3}{4}$ " ; $5'7\frac{9}{32}"$; $\frac{7}{8}"$ Bolt; Outer Elevation. &

Material for Reenforcing Bottom Chord:
1 Reenf. Pl., $24 \times \frac{13}{16} \times 6'6"$ outs. above Chord.
1 " " , $72" \times \frac{3}{4}" \times 8'0"$ next to Web.
1 " " , $72" \times 1" \times 6'9\frac{1}{2}"$ inside.
Outs. Stiffeners, $12L^S, 4" \times 5\frac{7}{16}" \times 3'10\frac{5}{8}"$
" Fillers, $6'8\frac{1}{2}" \times \frac{11}{16}" \times 2'11\frac{3}{4}"$
Diaphragms (Ins.), 3 Pl., $\frac{1}{2}"$ thick.

Material for I Chord Section:
2 Web Pl's, $24 \times \frac{5}{8} \times 25'0"$
2 " " , $16\frac{1}{2} \times \frac{9}{16} \times 25'0"$
1 Lat. Brace Pl., $37 \times \frac{1}{2} \times 6'0"$
2 " " Pl's, $11\frac{1}{2} \times \frac{1}{2} \times 1'10\frac{1}{2}"$
4 Batten Pl's, $15 \times \frac{3}{8} \times 2'1"$
4 L's, $4" \times 3\frac{1}{2} \times \frac{5}{8} \times 25'0"$

The Samples of Lettering on Lower Portion of this Plate show approximate Spacing of Lines and also Mode of Crowding in Fraction Numerals. It will also be seen that it becomes necessary to occasionally shorten a Capital or longer Lower Case Letter. Occasional Brackets or Horizontal Dashes are best made Free Hand; the latter with a slow, "wobbling" Stroke of the Pen.

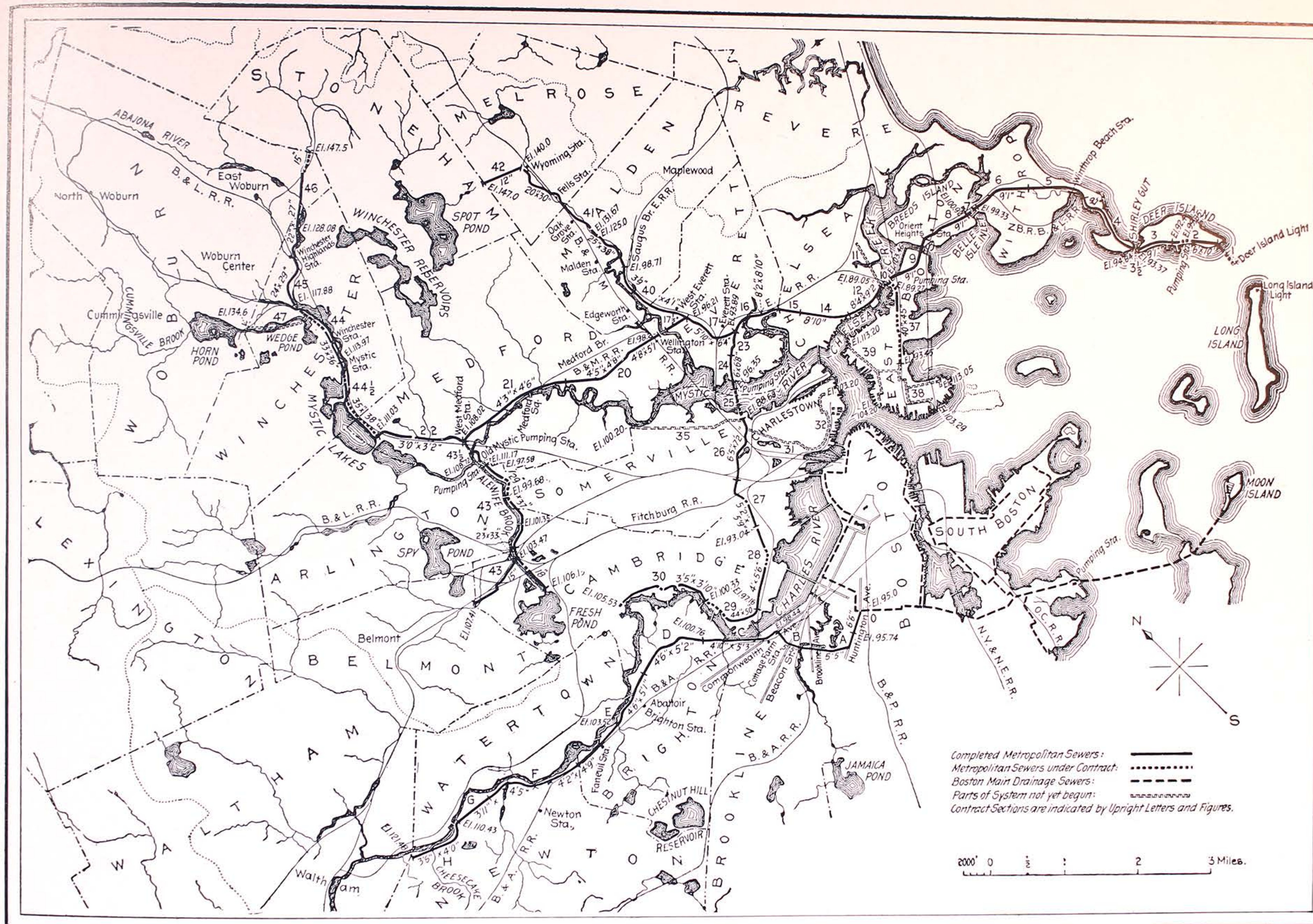

PLATE II.

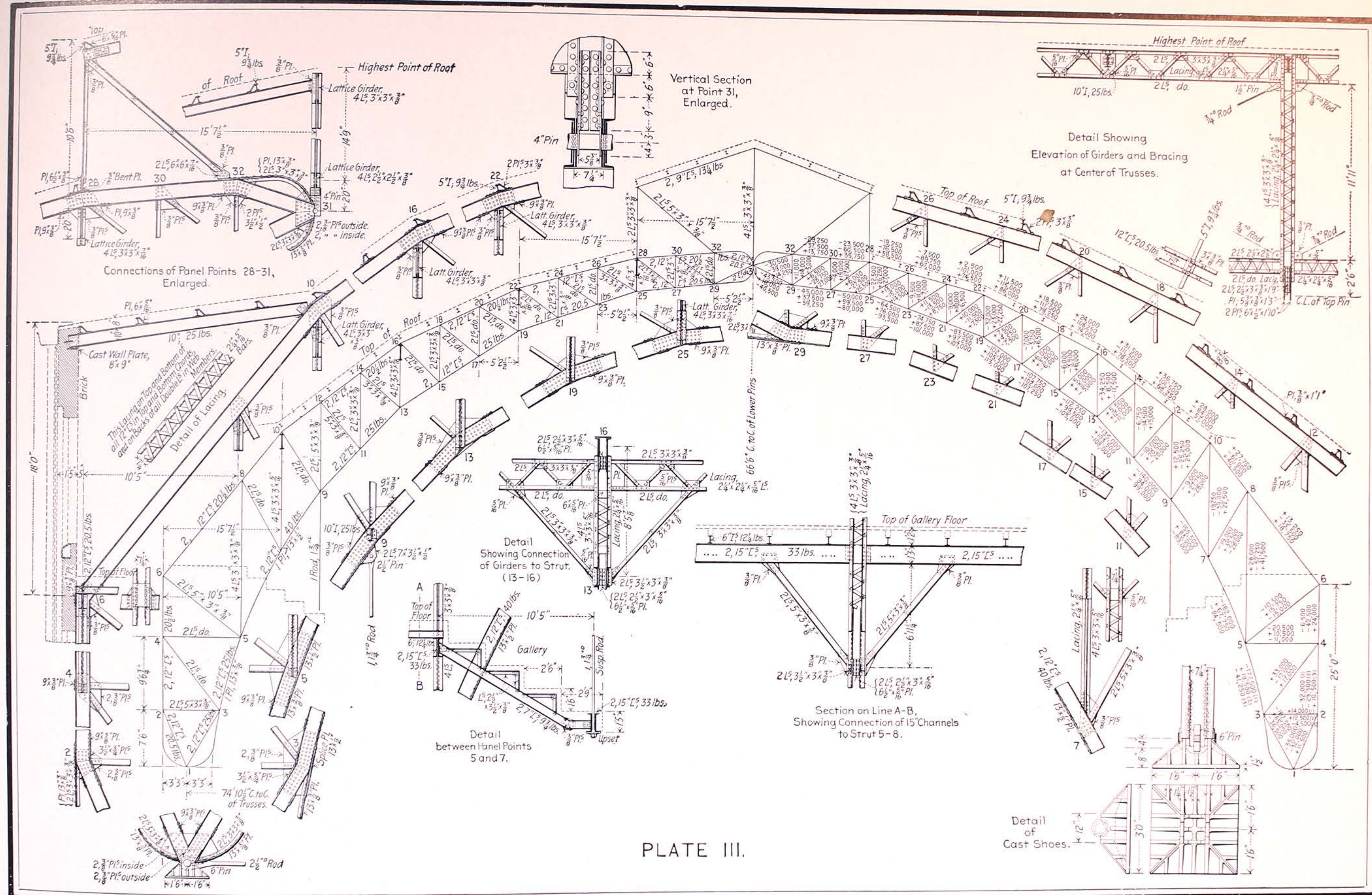

PLATE III.

a b c d e f g h i j k l m n o p q r s t u v w x y z
a² b² c¹ d² e² f³ g² h² i j k² l m² n² o² p² q² r² s² t² u² v² w² x² y² z²
A B C D E F G H I J K L M N O P Q R S T U V W X Y Z
A² B² C² D² E² F² G² H² I² J² K² L² M² N² O² P² Q² R² S² T² U² V² W² X² Y² Z²

Freehand

1 2 3 4 5 6 7 8 9 10.

Printing

2 3 4 5 6 7 8 9

Shaded Inclined (Italic) Lettering, Used for Working Drawings.

a b c d e f g h i j k l m n o p q r s t u v w x y z
 A B C D E F G H I J K L M N O P Q R S T U V W X Y Z

1 2 3 4 5 6 7 8 9 10.

Freehand Lettering for Captions, Produced very Fast.

THROUGH PASSENGER SERVICE; etc.



PLATE V



PLATE VI.

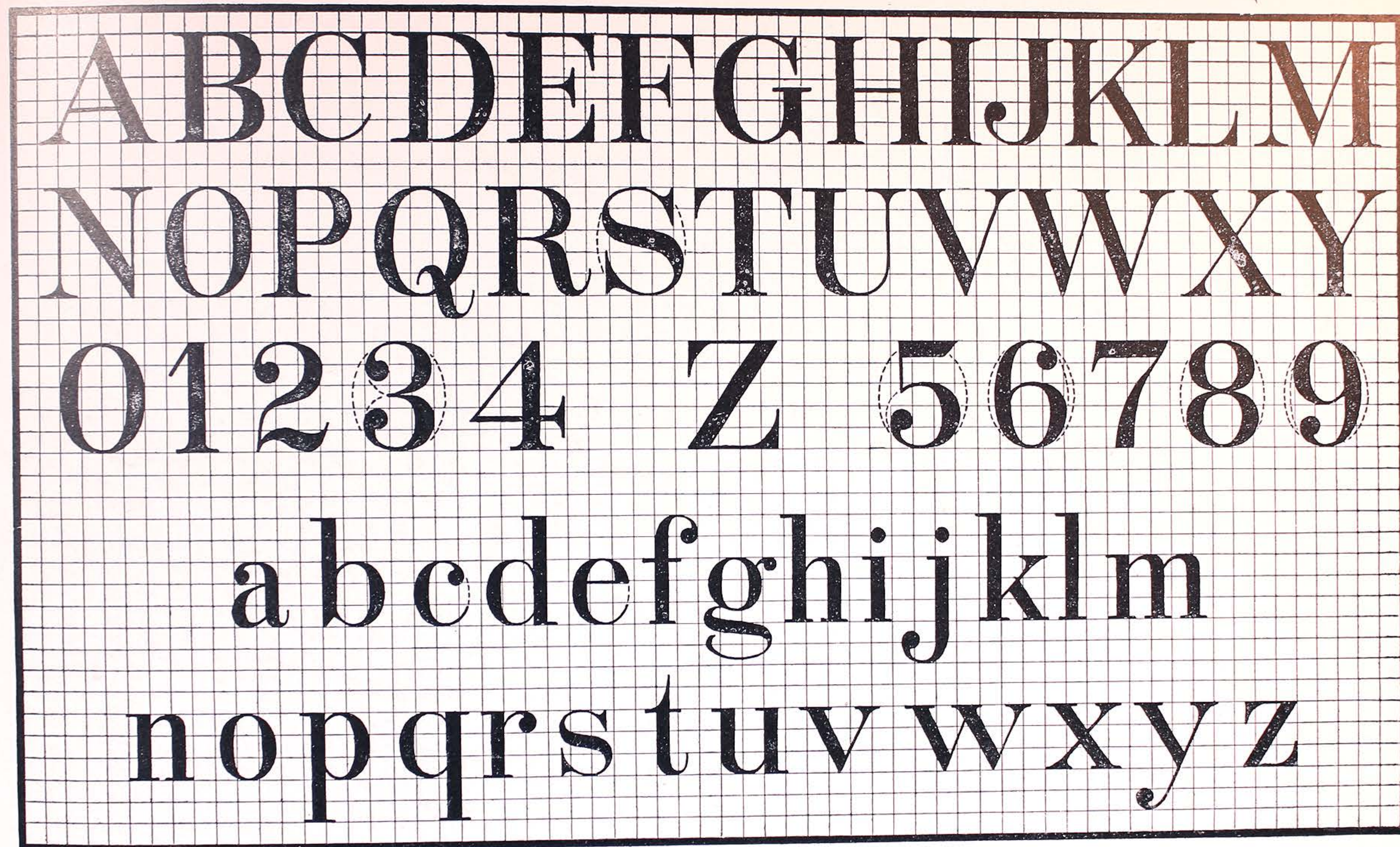
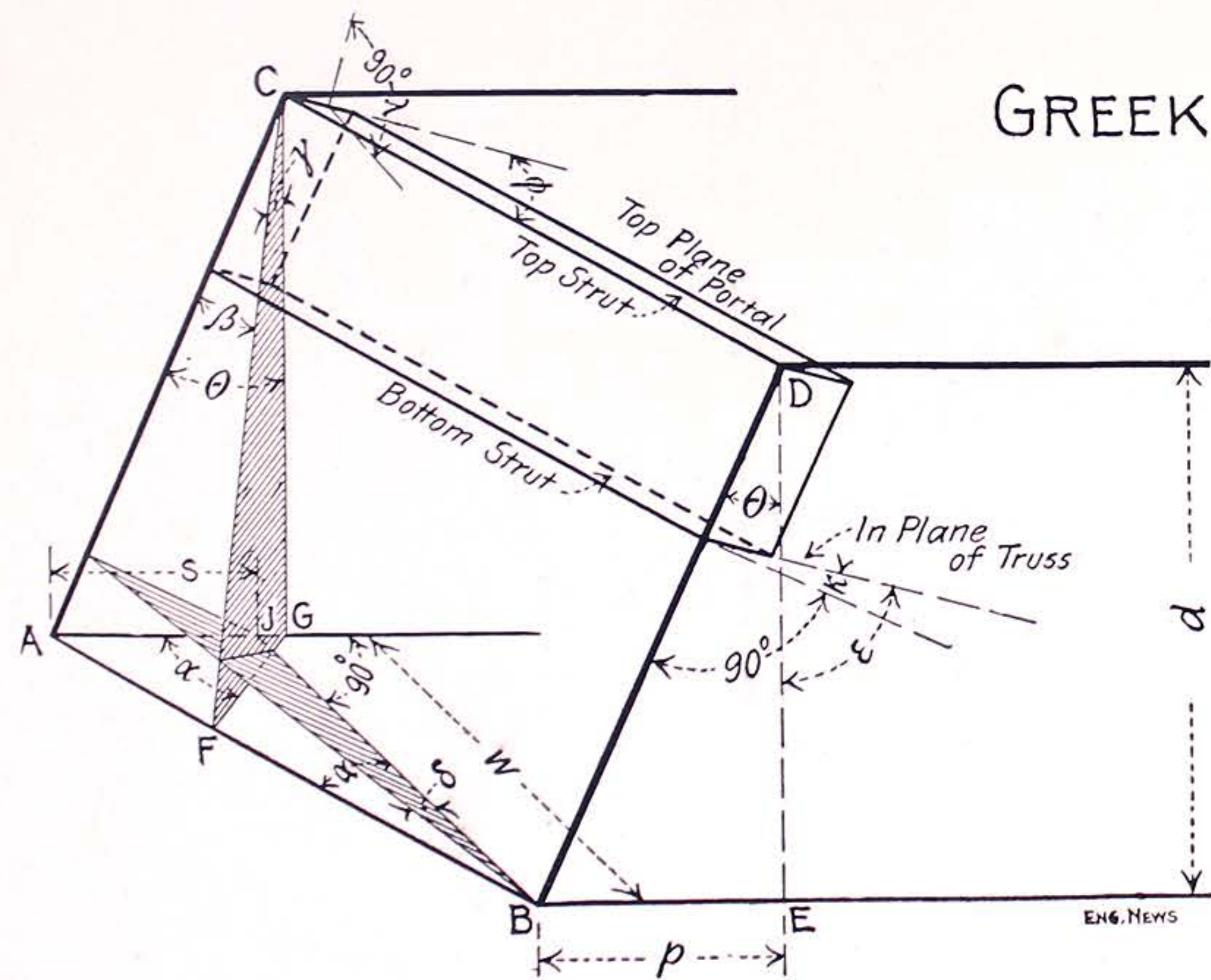

PLATE VII.

Alpha Beta Gamma Delta Epsilon Zeta Eta Theta Iota Kappa Lambda Mu Nu Xi Omikron Pi Rho Sigma Tau Upsilon Phi Chi Psi Omega
 α β γ δ ε ζ η θ ι κ λ μ ν ξ ο π ρ σ τ υ φ ψ χ ψ ω
 Α Β Γ Δ Ε Ζ Η Θ Ι Κ Λ Μ Ν Ξ Ο Π Ρ Σ Τ Υ Φ Χ Ψ Ω
 Α¹ Β² Γ¹ Δ² Ε¹ Ζ¹ Η¹ Θ¹ Ι¹ Κ¹ Λ¹ Μ¹ Ν¹ Ξ¹ Ο¹ Π¹ Ρ¹ Σ¹ Τ¹ Υ¹ Φ¹ Χ¹ Ψ¹ Ω¹



GREEK ALPHABET.
(SCRIPT)

Application
of
Alphabet.

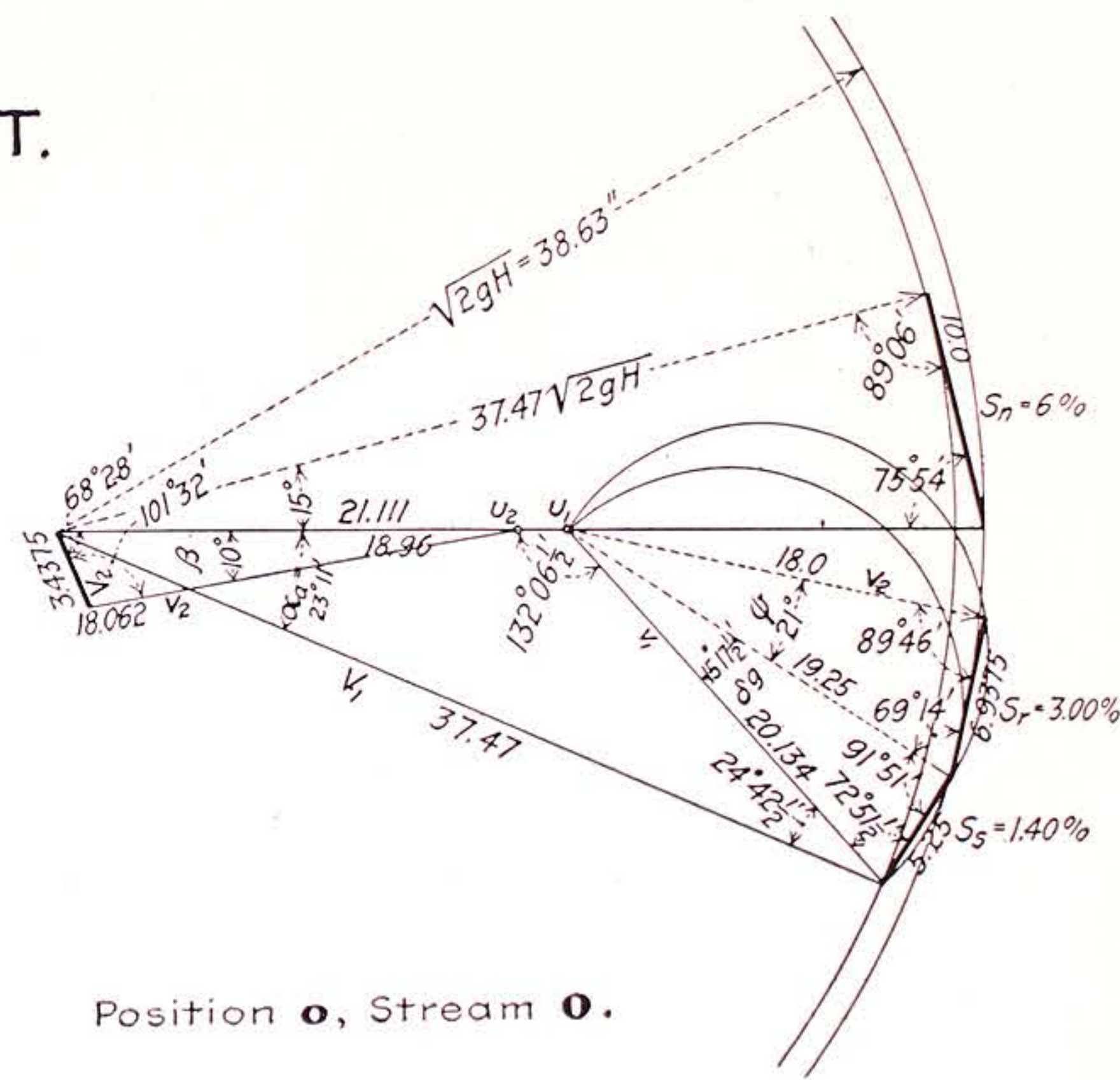

^{1 2 3 4 5 6 7 8 9 10 11 12 13 14 15 16 17 18}
 Station Map - Lands
^{1 2 3 4 5 6 7 8 9 10 11 12 13 14 15 16 17 18 19 20 21 22 23 24 25 26 27 28 29 30 31}
 New York and San Francisco R. R.
^{1 2 3 4 5 6 7 8 9 10 11 12 13 14 15}
 Operated by the
^{1 2 3 4 5 6 7 8 9 10 11 12 13 14 15 16 17 18 19 20 21}
 Gulf and Piedmont Ry.
^{1 2 3 4 5 6 7 8 9 10 11 12 13 14 15 16 17 18}
 Station 331 + 55 to
^{1 2 3 4 5 6 7 8 9 10 11 12 13 14 15}
 Station 542 + 75

^{1 2 3 4 5}
 Cuero
^{1 2 3 4 5 6 7 8 9 10 11 12 13}
 Water Works
^{1 2 3 4 5 6 7 8 9 10 11 12 13 14 15 16}
 Standard Details
^{1 2}
 of
^{1 2 3 4 5 6 7 8 9 10 11 12 13 14 15 16 17 18 19}
 Lifters for Screens
^{1 2 3 4 5 6 7 8 9 10 11 12 13 14 15 16}
 and Stop - Planks.

STATION MAP - LANDS
 NEW YORK AND SAN FRANCISCO R. R.
 Operated by the
 GULF AND PIEDMONT RY.
 STATION 331 + 55 TO
 STATION 542 + 75

CUERO
 WATER - WORKS
 STANDARD DETAILS
 OF
 LIFTERS FOR SCREENS
 AND STOP - PLANKS

This title was first penciled in on Cross-Section Paper; in tracing on original map this paper was shifted sideways for each line, so as to get centers lined up with general Center-Line of title here. Each line is to be finished just as indicated. In lines 1, 2 and 4 the tops and bottoms of letters are finished off by freehand touches. The fine outlining for shade-line strokes in line 4 will wonderfully help appearances.

Purely single-stroke lettering used here without any fixing up. Here a single system of counting a space for a letter, etc., was followed in the laying out. Title is to be finished up carefully, according to faintly outlined suggestions given. The prominence or height of portions of title depends upon their relative importance and perhaps the taste of draftsman.

TITLES CONSTRUCTED BY MEANS OF COUNTING LETTERS AND DETERMINING CENTERS FOR INDIVIDUAL LINES.

Map
of the
State of New York
Showing the Confined Location of
Westchester County

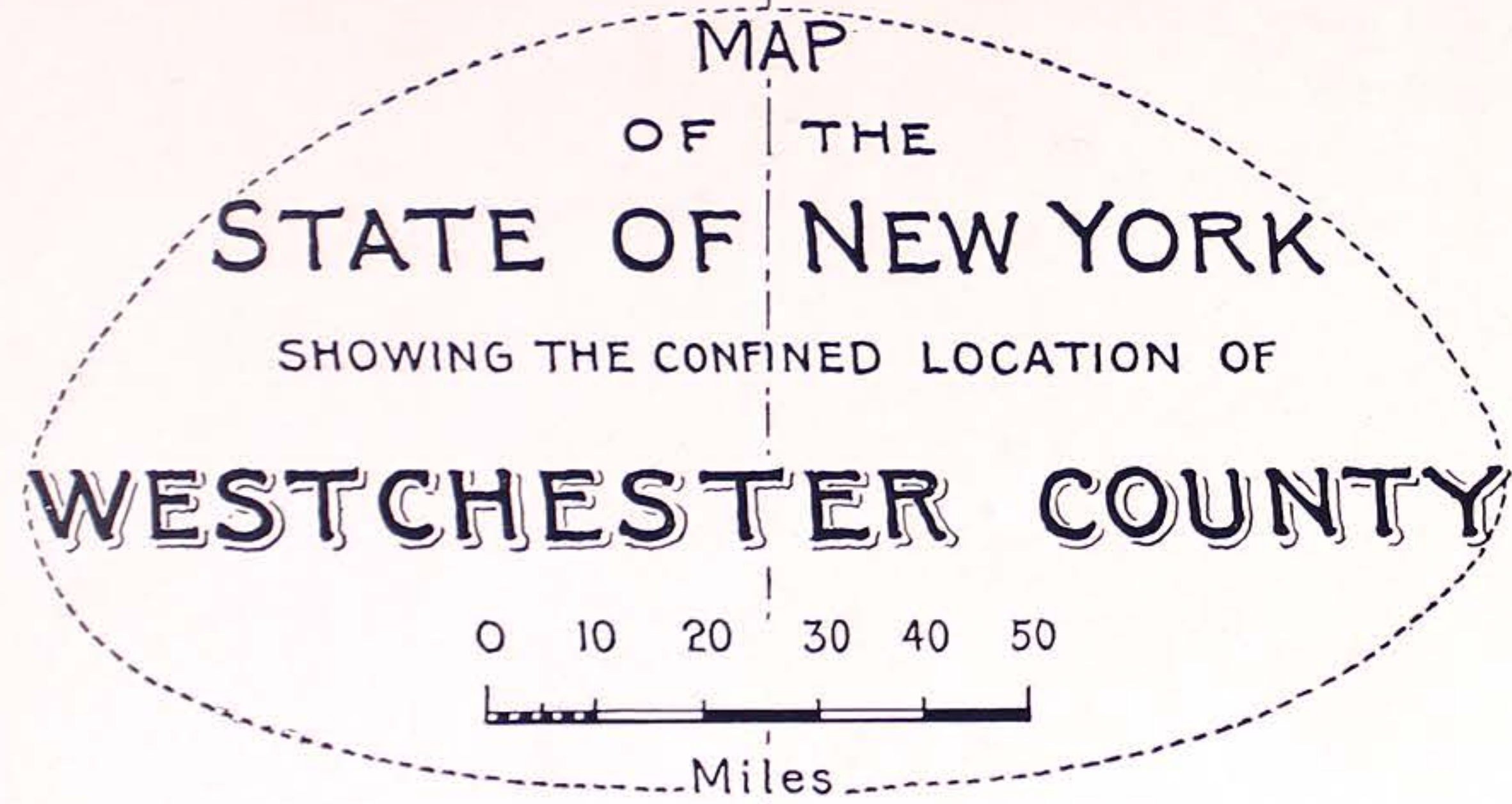

After Center of Line was determined, each Line was penciled in from *Center to Right*; afterward the Part at Left of Center Line from *Right to Left*.

Above title shows how Fullness or Rounding off is attained by adding scale, instead of dashes, as shown elsewhere.



Letters at Right left purposely unfinished. Draw in all letters freehand, rule in tops and bottoms. To be filled in as indicated, tracing entire title in finished shape.

TWO UNUSUAL SHAPES OF TITLES SHOWN HERE.

Details
Suspended Car Transfer
Ship Canal - Duluth, Minn.

C. A. P. Turner - Engineer.
816-Phoenix Bldg. Minneapolis, Minn.

June 14, 1900.

Apparatus for the
Aeration of Water.

Scale $\frac{1}{2}'' = 1'$.

William Wheeler,
Consulting Engineer,

NORTH GERMAN LLOYD,

PLANS FOR

PROPOSED PIER NO. 3,

(90 FT. WIDE.)

HOBOKEN, N. J.

OCT. 1900.

*W. F. W., Civil Engineer,
Hoboken, New Jersey.*

*ARRANGEMENT OF
INSIDE SHORING
PREPARATORY TO DOCKING.
U. S. S. OREGON.*

NAVY YARD, PUGET SOUND.

OCTOBER, 15, 1901.

Commonwealth of Massachusetts.
Metropolitan Water Works.

STANDARD DETAILS

OF

LIFTERS FOR SCREENS

AND

STOP - PLANKS.

Full Size

— TESTING STATION. —

— OF THE —

— COLUMBIAN FIREPROOFING CO. —

— BOSTON, MASS. —

COMMONWEALTH OF MASSACHUSETTS.
METROPOLITAN WATER WORKS.
WACHUSETT DAM.

GENERAL PLAN OF DAM
AND APPURTENANCES.

0 40 80 120 160 200 FT.

*RAPID TRANSIT RAILROAD COMMISSION
SEWER DIVISION*

*TYPICAL PLAN
FOR
ALIGNMENT OF 2'-4" x 3'-6" BRICK SEWER
AROUND
ELECTRIC MANHOLE
SCALE: 1/2" = 1'*

New York & Brooklyn Bridge
Present Details of Bottom Connections
Suspenders & Stays.
Scale 3/4 in. to 1 ft. Sept. 1901.

ROUND CORNER DETAILS.

SCALE 1/2 INCH=1 FT.

These details for S.E. Corner—Similar construction at N.E. corner.

*—BOONE COUNTY RY.—
—DES MOINES RIVER VIADUCT.—
General Elevation, Cross Sections & Splices
Scale 1/2", 1 1/2" = 1 ft.*

*Chief Engineers Office.
Chicago & North-Western Ry.
Chicago. Dec. 30th 99.—*

Approved

Consulting Eng'r. Drawing No 2781

33
33

PITTSBURGH, PA.
**DEPARTMENT OF PUBLIC WORKS
BUREAU OF FILTRATION**

CONTRACT NO. 1
FILTERS, BASINS AND APPURTENANCES
INTERIOR DRAINS
DETAIL PLAN OF ONE FILTER

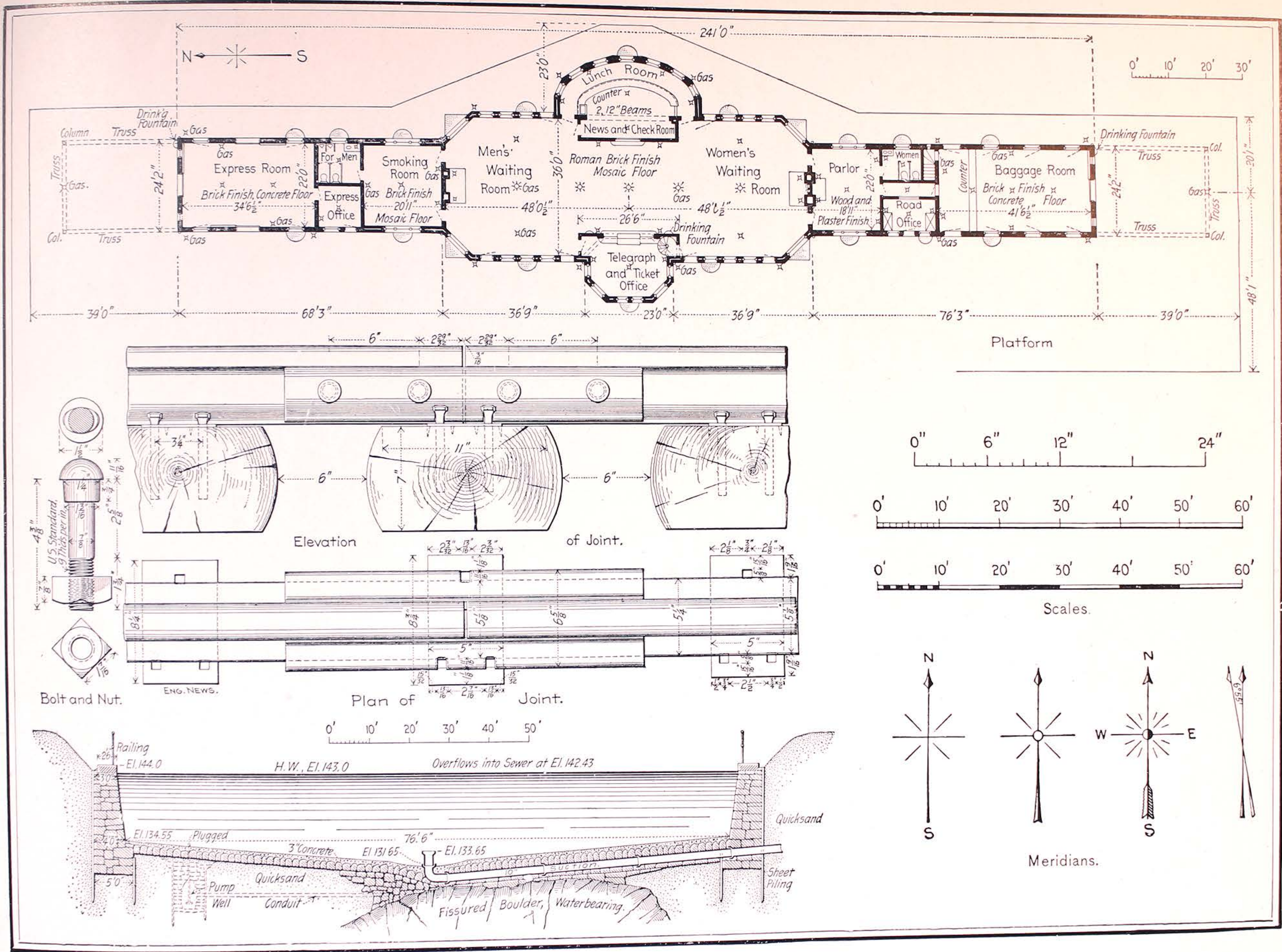

PLATE XIV.

STANDARD TEXTS FOR DRAFTSMEN

PUBLISHED BY

D. VAN NOSTRAND COMPANY, 25 Park Place, New York

A PRACTICAL COURSE IN MECHANICAL DRAWING

By **WILLIAM FOX, M. E.**

Assistant Professor of Applied Mathematics,
College of the City of New York, and

CHARLES W. THOMAS, M. E.

Instructor in Descriptive Geometry and Drawing,
College of the City of New York

The object of this work is to provide a simple, practical course of progressive lessons in Mechanical Drawing. It will be noticed that all instructions are given in connection with a special, concrete exercise.

No practical draughtsman will criticize us for not starting with the traditional geometric problems. We have reason to believe that the average student does not appreciate these subjects if introduced *before* their bearing and practical application are understood.

Contents: USE OF INSTRUMENTS, DIMENSION LINES, DRAWING TO SCALE, CENTER LINES, DIVIDERS, BOWPEN, SECTIONS, SHADING, LETTERING, SCREWS, COG-WHEELS, READING OF DRAWINGS, MISCELLANEOUS.

THIRD EDITION REVISED

98 Pages, 5½ x 8

87 Illustrations

Price, \$1.25 Net

PART I NOW READY 70 Pages, 6 x 9 Illustrated MACHINE DRAFTING AND EMPIRICAL DESIGN

A Text Book for Students in Engineering Schools, and others who are Beginning the **Study of Drawing** as Applied to Machine Design

BY
WALTER RAUTENSTRAUCH
Adj. Professor Columbia University

AND
JOHN T. WILLIAMS
Instructor Cornell University

Complete in Two Parts

Part I. BEGINNING DRAFTING, SKETCHING, ETC.—The aim of the first part is to not only give the student practice in the making of good line drawings, intersections, the principles of construction, etc., but by a proper selection of practical examples to impart to him information of a practical nature, such as every designer should know. A definite system of standards is arranged with a view to its being followed throughout the course.

IN PRESS

Part II. EMPIRICAL DESIGN—The second part is intended to give the student an idea of proportion. Numerous tables of proportions of parts that have become standard, formulas, etc., are provided as well as many problems from which a course of study may be arranged. It is arranged to thoroughly train the student to take up "Advance Machine Design."

Price, each, \$1.25 Net

ALPHABETS AND OTHER MATERIAL USEFUL TO LETTERERS

BY
CHARLES ROLLINSON

The various styles of letters contained in this volume are those most useful to the beginner, as well as to the professional engrosser. There are twenty-seven pages of carefully prepared alphabets printed from plates made direct from pen and ink copy by the author, and these combine the fundamental principles of working with the necessary examples of lettering as employed in mechanical work, as well as the more ornate forms as applied to the advanced styles employed by illuminators.

LIST OF PLATES

Business Script. Business Letter. Spencerian; Capitals, Lower Case. English Script; Capitals, Lower Case, Ornate. Roman. Block. Old English. Modified Old English. German Text. Gothic Mediaeval. Sickel's; Ornate. German Round-Hand. German Round Hand Modified. Broad Point. Borders and North Points. Roman Letters and Some Modifications. French Script. Italian. Monograms. Completed Work (3 specimens).

Shows work of a high order that is of a practical kind, such as penmen, engrossers, letterers, draftsmen, etc., need as a guide. This is the most practical book of its character for general use now on the market.

33 Pages 9½ x 6¼ Inches 27 Plates Cloth

Price, \$1.00 Net

LEEDS' SERIES OF MECHANICAL DRAWING TEXT BOOKS



THESE books teach mechanical drawing by a method that develops the student's creative faculties. That faculty of imagining; that mental picturing, so necessary to the good draftsman or designer, and to the man in the shop who works from drawings, can be developed within every student. It is part of the development, just as an understanding of the meaning (either definite or conventional) of each line of a drawing is part of his development. Convinced of this fact, the author has arranged these lessons in a manner which he believes will attract and hold the interest of the student. Each lesson will guide the student by easy steps, illustrate some fundamental point in mechanical drawing, and work as a whole towards the development of the creative draftsman. Considerable new subject matter has been added in the new editions and the fundamentals are much more clearly presented than formerly. Some of the lessons in the two books are identical. The trade school book gives advanced work on machine construction while the other book devotes a few lessons to architectural drawing.

MECHANICAL DRAWING FOR TRADE SCHOOLS

By CHARLES C. LEEDS
Professor of Mechanical Drawing, School of Applied
Industries, Carnegie Institute of Technology.

61 LESSONS

PREPARATION of Pencils; Handling T-Square, Triangles, etc., Preparation and Use of Instruments; Drawing of Flanged Pin; Drawing of Machine Bolt; Lettering Figures; Sketching; Tracing; Machine Bolt; Hidden Surfaces; Clamp; Sectioning; Sleeve; Orthographic Projection; Shaft Support; Tool Rest; Projection; Unfinished Views; Reference Matter; True Section; Flanged Pulley; Conventional Sections; Hand Wheel; Drawing to Scale; Face Plate; Coupling Assembly; Bill of Materials; Coupling; Problems in Projection; Geometrical Problems; The Ellipse; Engineering Curves; Spur Gearing; Pulley; Specification; Conic Sections; Intersections and Developments, Parallel; Line; Radial Line; Triangulation Development; Spur Gear Specifications; Bevel Gearing; Isometric Projection; 12-Inch Speed Lathe; Leg Details, Bed Details, Tool Rest Details, Tool Rest Assembly, Tailstock Details, Tailstock Assembly; Headstock Details; Headstock Assembly; Specification; Lathe General Assembly; Standard Data; Composite Drawing; Bench Grinder Details; Specification; Bench Grinder Assembly; Commutator Bar; Front; Commutator Ring; Rear Commutator Ring; Armature Spider; Specification; Commutator Assembly; Generator Frame; Worm Gearing; Plate Cam; Periphery Cam; Structural Work; Rivets and Conventional Symbols; Riveted Joints; Standard Framing; Beam Connections.

THIRD REVISED EDITION

10 $\frac{3}{4}$ x 8 Inches

150 Pages

Illustrated

NET \$2.00

MECHANICAL DRAWING FOR INDUSTRIAL AND HIGH SCHOOLS

By CHARLES C. LEEDS
Professor of Mechanical Drawing, School of Applied
Industries, Carnegie Institute of Technology.

39 LESSONS

INTRODUCTION, Pencil, Paper, Drawing Board, T-Square, Triangles, Measurements, Drawing to Measurements, Compass Points, Rounded Corners, Fillets, Construction Circles, Nuts, Lettering, Figures, Machine Bolt, Screw Threads, Hidden Surfaces, Clamp, Sectioning, Orthographic Projection, Shaft Support, Tool Rest Problems in Projection, Unfinished Views, Sketching, Sketching, Proportions, Reference Matter, Hinged Pulley, Projection, Geometrical Problems, The Ellipse, Method of Holding Pen, Tracing Cloth, Care of Pens, Tracing Machine Bolt, Finished Drawing, Hand Wheel, Drawing to Scale, Assembly Drawing, Coupling, Compression Shaft Coupling, Drawing from a Specification, Engineering Curves, Conic Sections, Isometric Projection, Isometric Drawing, Coordinate Axes, Isometric Circles, Broom Holder, Wall Shelf, 12 inch Speed Lathe—Tool Rest Details, 12 inch Speed Lathe—Tool Rest Assembly, 12 inch Speed Lathe—Tailstock Details, 12 inch Speed Lathe—Tailstock Details, 12 inch Speed Lathe—Tailstock Assembly, Architectural Drawings Basement Plan, First Floor Plan, Second Floor Plan.

THIRD EDITION, REVISED AND ENLARGED

10 $\frac{3}{4}$ x 8 Inches

92 Pages

Illustrated

NET \$1.25

PE

Mem
This b
intended
without th
experience
form him
science.
Manipulat
subject is
way, the
in the dra
well as in

I.
III. M
IV. Se
Vanish
VI. M
Paralle
Specia
IX. Va
Lines
of Sha
spectiv

and a
student
the m
Layme
knowl
tle bo

111 Pag

D.

PERSPECTIVE

AN ELEMENTARY TEXTBOOK

By BEN J. LUBSCHEZ

Member of the American Institute of Architects

This book is a concise treatise on Perspective primarily intended for home study by the beginner or draftsman without the aid of a teacher, but also of great value to the experienced draftsman and to the layman wishing to inform himself regarding the general principles of the science. It contains a chapter on Short Cuts and Special Manipulations of great value to any worker. The whole subject is very clearly and simply presented in a unique way, the text being the result of many years of experience in the drawing of Perspectives in an architect's office, as well as in teaching the subject to beginners.

CONTENTS

I. Introductory. II. Preliminary.
III. Making a Drawing in Perspective.
IV. Second Problem in Perspective. V.
Vanishing Points and the Point of Station.
VI. Measuring Points and Scales. VII.
Parallel or One-Point Perspective. VIII.
Special Manipulations and Short-Cuts.
IX. Variations. X. Oblique and Inclined
Lines and Planes. XI. The Perspective
of Shadows (By sunlight). XII. The Per-
spective of Shadows (By artificial light).

"It begins absolutely at the beginning, and a careful study of it will enable the student to read understandingly and study the more advanced books on the subject. Laymen, also, who wish a mere general knowledge of the science, will find the little book profitable reading."

Architecture and Building, June, 1913.

SECOND EDITION ENLARGED

111 Pages 36 Illustrations 5x7½ in. 8 Folding Plates

Price, \$1.50 Net

THEORY OF Engineering Drawing

By ALPHONSE A. ADLER, B.S., M.E.

Instructor in Mechanical Drawing and Designing,
Polytechnic Institute of Brooklyn

*An unusually complete, thorough course,
treating the subject matter in a radically and
rationally new way.*

The text is divided into four parts as follows:

PART I. "Principles of Parallel Projecting-Line Drawing," also printed and bound separately. (See book below.)

PART II treats of the usual problems found in the various Descriptive Geometries; the Classification of Lines and Surfaces; and Intersections and Developments. The problems are numerous and cover nearly every phase of the subject. Warped Surfaces are not included, as the author did not think these essential in view of the more important material which is usually omitted.

PART III treats of Perspective Projection and gives this subject in much better form than is now obtainable.

PART IV treats of the Pictorial Effects of Illumination and is that part which is usually headed, "Shades and Shadows."

328 Pages, 6x9 275 Illustrations

Price, \$2.00 Net

THE PRINCIPLES OF Parallel Projecting- Line Drawing

By ALPHONSE A. ADLER, B.S., M.E.

Instructor in Mechanical Drawing and Designing,
Polytechnic Institute of Brooklyn

A complete and concise discussion of the rapid methods of making drawings that find wide application in drafting rooms. Arranged by topics so that reference to a particular type of projection is easily accomplished. The complete classification of the types of projection makes an excellent survey of the entire subject. It is a book that teaches principles rather than methods, and for this reason it should be useful as a text for elementary instruction in drawing, since it approaches the subject in an interesting manner. The book contains four chapters as follows: 1. Introductory. 2. Oblique Projection. 3. Orthographic Projection. 4. Axonometric Projection. Each chapter shows the commercial application of the type of projection considered, and gives a set of questions which thoroughly cover the text. A complete index is also included.

72 Pages, 6x9 48 Illustrations

Price, \$1.00 Net

ELEMENTARY COURSE IN PERSPECTIVE

By SHERMAN M. TURRILL

Civil Engineer, Assoc. Am. Soc. C. E.

This book shows the mechanical application of the principles of descriptive geometry to the making of a perspective drawing. Two methods are explained—the "Method by the Use of the Plan," which requires the use of instruments and is intended for the mechanical draftsman, while the "Method by Scale" is the quicker process where the accurate location of the leading or important points only is desired, and is helpful for the freehand draftsman and artist. There are eighty-eight problems for solution by either method covering the principles as applied to the illustrated subject in a variety of position.

CONTENTS

METHOD BY ORTHOGRAPHIC PROJECTION: Definitions and Descriptions. Notation. Pictorial Perspective of a Pyramid. Perspective of: a Pyramid; a Building; a Cube and Parallelopiped; a Plane Curve; a Cylinder; the Shadow of the Frustrum of a Pyramid by Use of the Horizontal Projection of the Shadow; the Shadow of the Frustrum of a Pyramid by the Method of the Vanishing Point of Rays; a Shadow of a Cube and Parallelopiped; the Shadow of the Frustrum of a Pyramid on an Oblique Plane. Problem. METHOD BY SCALE: Comparison of the Two Methods. Perspective of: a Pyramid; a Building; a Cube and Parallelopiped; a Cylinder; the Shadow of a Cube and Parallelopiped. Problems.

81 Pages, 5x7½ 16 Illustrations and
Folding Plates

Price, \$1.25 Net

D. VAN NOSTRAND COMPANY - Publishers - 25 Park Place, New York

THE LITERATURE OF ENGINEERING

On our shelves is the most complete stock of technical, industrial, engineering and scientific books in the United States. A large number of these we publish and for an ever increasing number of American and foreign books we are the sole agents.

ALL OUR INQUIRIES ARE CHEERFULLY AND CAREFULLY ANSWERED AND COMPLETE CATALOGS AS WELL AS SPECIAL LISTS ARE SENT FREE ON REQUEST



D. VAN NOSTRAND COMPANY

PUBLISHERS AND BOOKSELLERS

25 PARK PLACE

NEW YORK

